

Heat Recovery Units Direct Drive

with

EC Motors

Plant and Roof



*ventilation
systems*



Counter Flow Heat Recovery - 0.07 m³/sec to 4.00 m³/sec



Features and Benefits

Heat Recovery Units - EC Motors

- Up to 90% efficient
- ErP compliant 2009/125/EC
- EC fans to suit L2
- Fitted Controls

Low energy use - Direct Drive EC Fans

- Energy efficient EC fans to meet L2 regulations
- Built in speed control as standard

Counter flow Heat Exchanger for increased energy recovery

- ErP compliant heat exchangers up to 90% efficient
- Most applications will not require top-up heating
- Complete with face and bypass for summer ventilation

F7 and M5 filters fitted as standard

- Grade F7 (supply) and M5 (extract) filters to meet ErP regulations

Enhanced case construction to reduce noise breakout

- 25mm double skin construction with rockwool on all units
- 40mm on underside of smaller internal units to reduce noise breakout
- Acoustic high-density infill option available

Slim-line construction to assist installation in restricted areas

- Internal units have reduced height to fit restricted ceiling voids

Multiple access for easy maintenance

- Units are side access as standard. Optional bottom or top access available
- Optional extended mounting feet to suit drop rods if required

Flexible design to suit your location

- Internal units available flat or stacked configuration
- External units available flat or stacked configuration.

Integrated energy saving controls for peace of mind

- Factory fitted controls available saving time and money on site
- Full range of basic and enhanced versions to suit most requirements
- Demand ventilation via CO₂ or PIR

Accessories

- Top up Heater modules Electric
- Top up Heater modules LPHW
- Silencers direct fit to unit

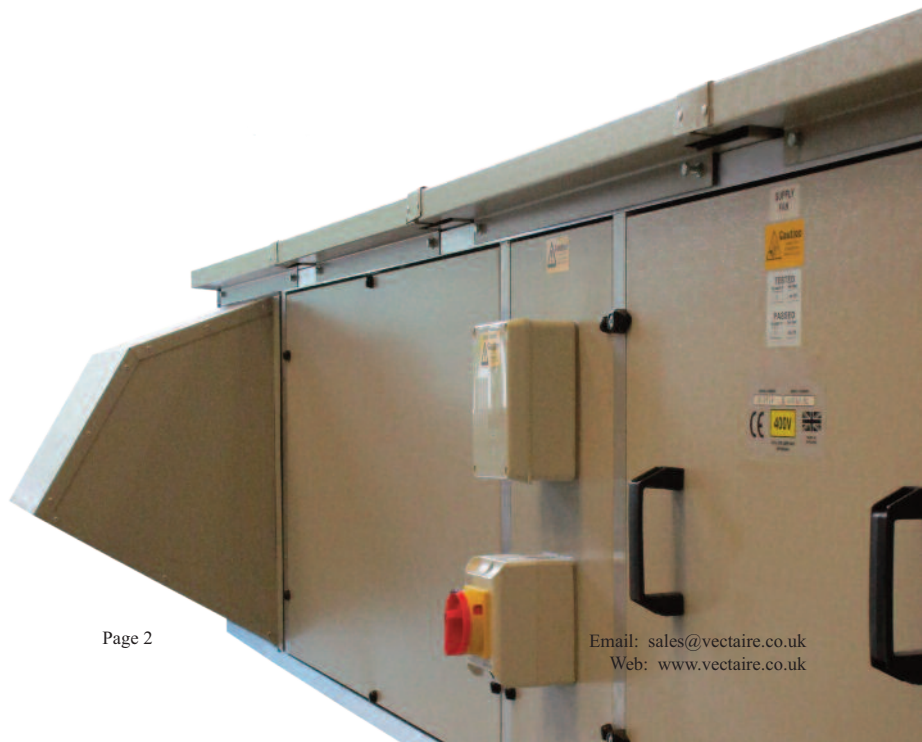



Selection Chart

Maximum Air Volume (m³/sec)

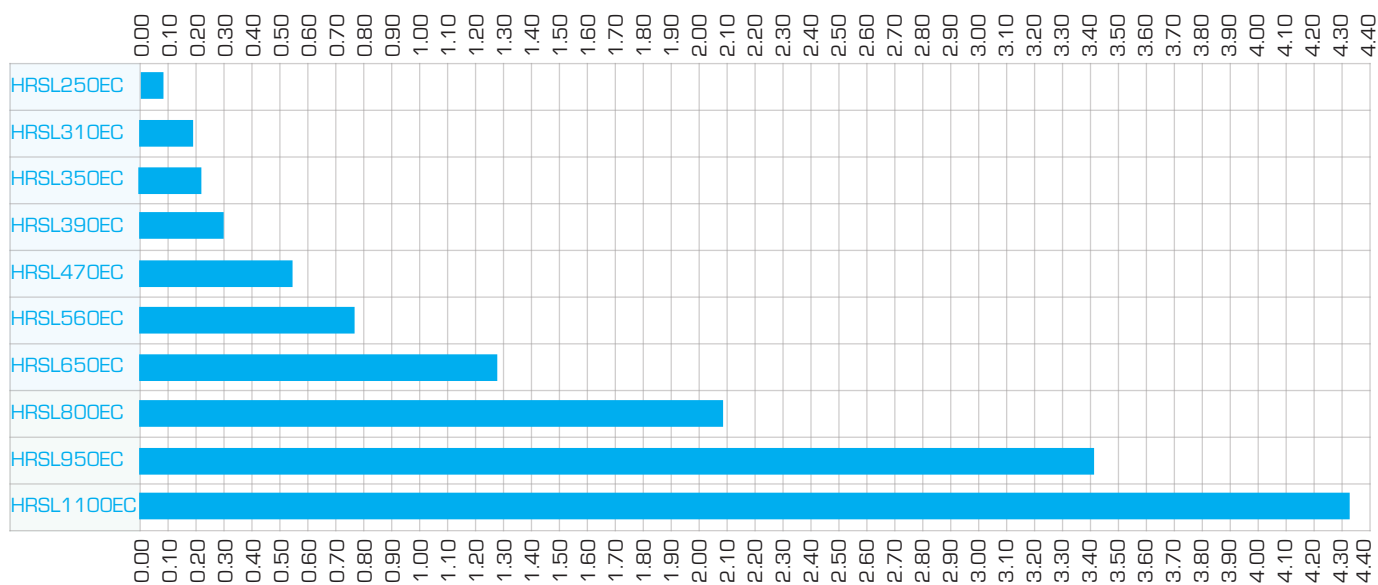

Range available:

- HRPSL-EC - plant models, side by side
- HRPSL-EC/BA - plant models, bottom access
- HRPSL-EC/STK - plant models, stacked

- HRRSL-EC - roof models, side by side
- HRRSL-EC/STK - roof models, stacked



TECHNICAL DATA - HRPSL250EC

FAN SPEED

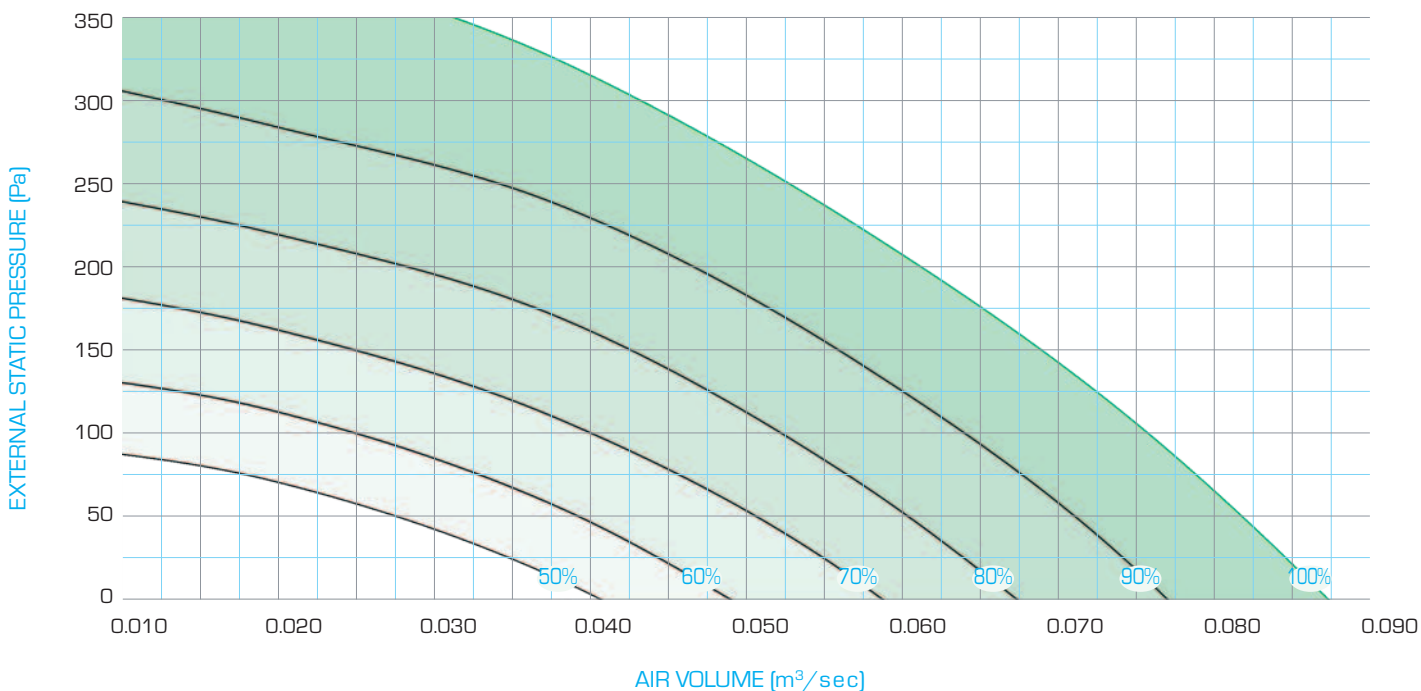

ELECTRICAL DATA per FAN
 Maximum drawn current for UNIT - 6A
 (fuse/ circuit breaker rating does NOT include ancillaries)

MODEL	FAN POWER W	SUPPLY	FLC amps
HRPSL250EC	50	230V 1Ph	0.46

HRPSL250EC @ mid duty		Mid Octave Frequency band / Hz								Total in Duct		In Duct @ 1m		In Duct @ 3m		Breakout @ 1m		Breakout @ 3m	
		63	125	250	500	1k	2k	4k	8k	dB	dB(A)	dB	dB(A)	dB	dB(A)	dB(A)	NR	dB(A)	NR
0.045m³/s @100%	Inlet in duct dB	63	69	69	69	63	60	57	50	75	70	62	58	52	48	47	45	37	35
	Outlet in duct dB	68	74	74	74	68	65	62	55	75	67	67	63	57	53				
0.040m³/s @90%	Inlet in duct dB	61	66	66	67	60	57	53	46	72	67	59	56	49	46	44	42	34	32
	Outlet in duct dB	66	71	71	72	65	62	58	51	77	72	64	61	54	51				
0.035m³/s @80%	Inlet in duct dB	59	64	63	64	58	54	50	42	69	64	56	53	47	43	41	39	32	28
	Outlet in duct dB	64	69	68	69	63	59	55	47	74	69	61	58	52	48				
0.030m³/s @70%	Inlet in duct dB	57	62	60	61	55	51	46	38	67	61	56	49	44	40	38	36	29	25
	Outlet in duct dB	62	67	65	67	60	56	51	43	72	67	59	56	49	46				
0.025m³/s @60%	Inlet in duct dB	54	59	59	57	51	47	42	33	64	58	50	45	40	36	36	33	26	23
	Outlet in duct dB	59	64	62	62	56	52	47	38	69	62	54	51	45	41				
0.020m³/s @50%	Inlet in duct dB	51	55	53	53	47	43	37	26	60	53	45	45	36	31	31	28	22	18
	Outlet in duct dB	56	60	58	58	52	48	42	31	65	58	50	50	41	37				



TECHNICAL DATA - HRPSL250EC

SPECIFIC FAN POWER - FOR EACH FAN

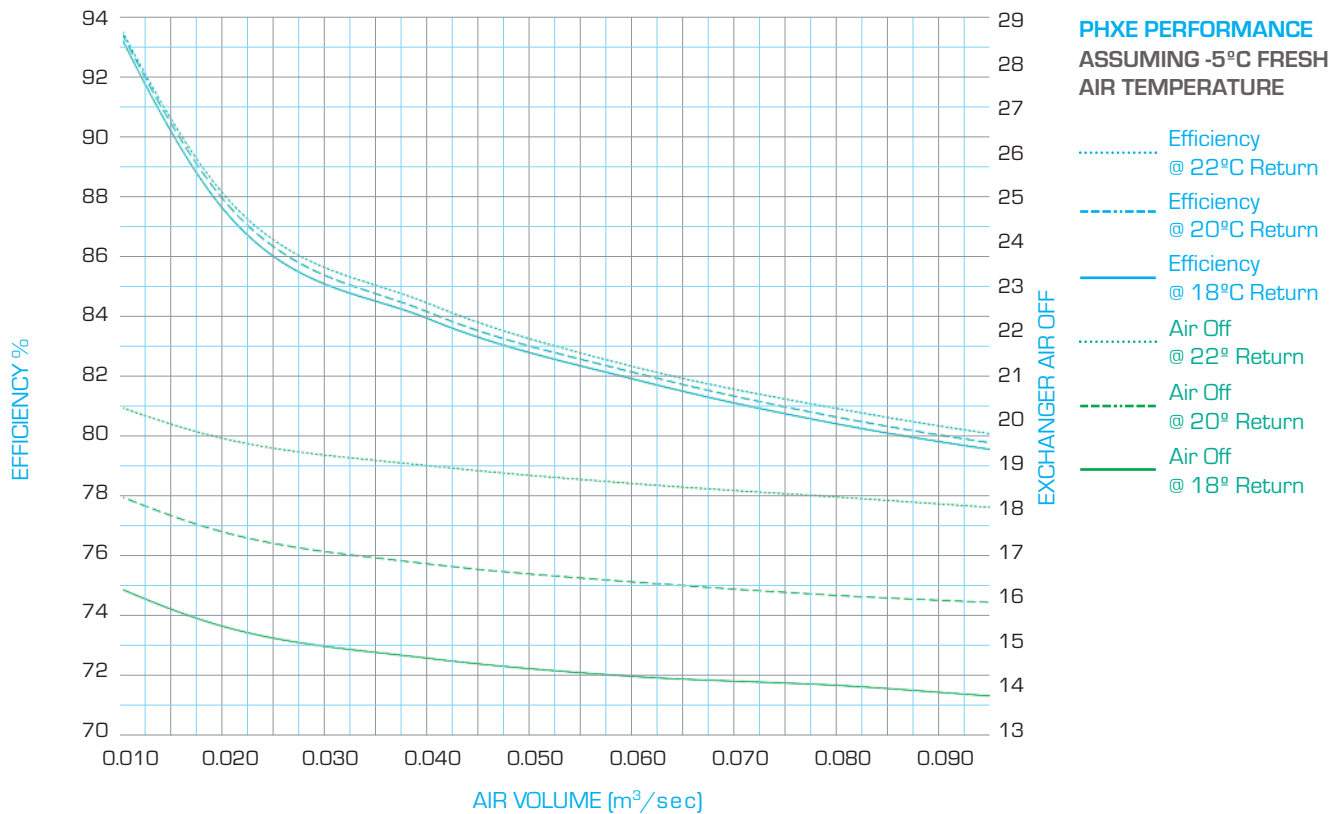
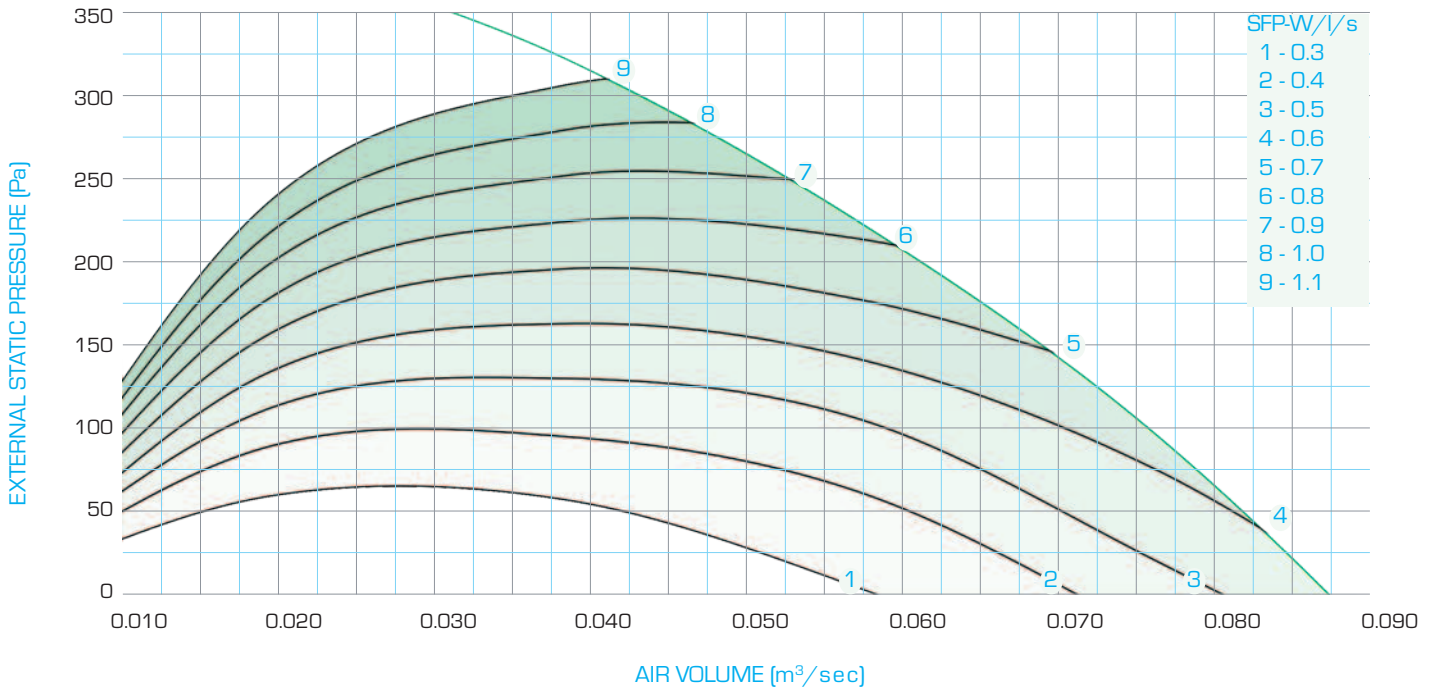



TECHNICAL DATA - HRPSL310EC

FAN SPEED

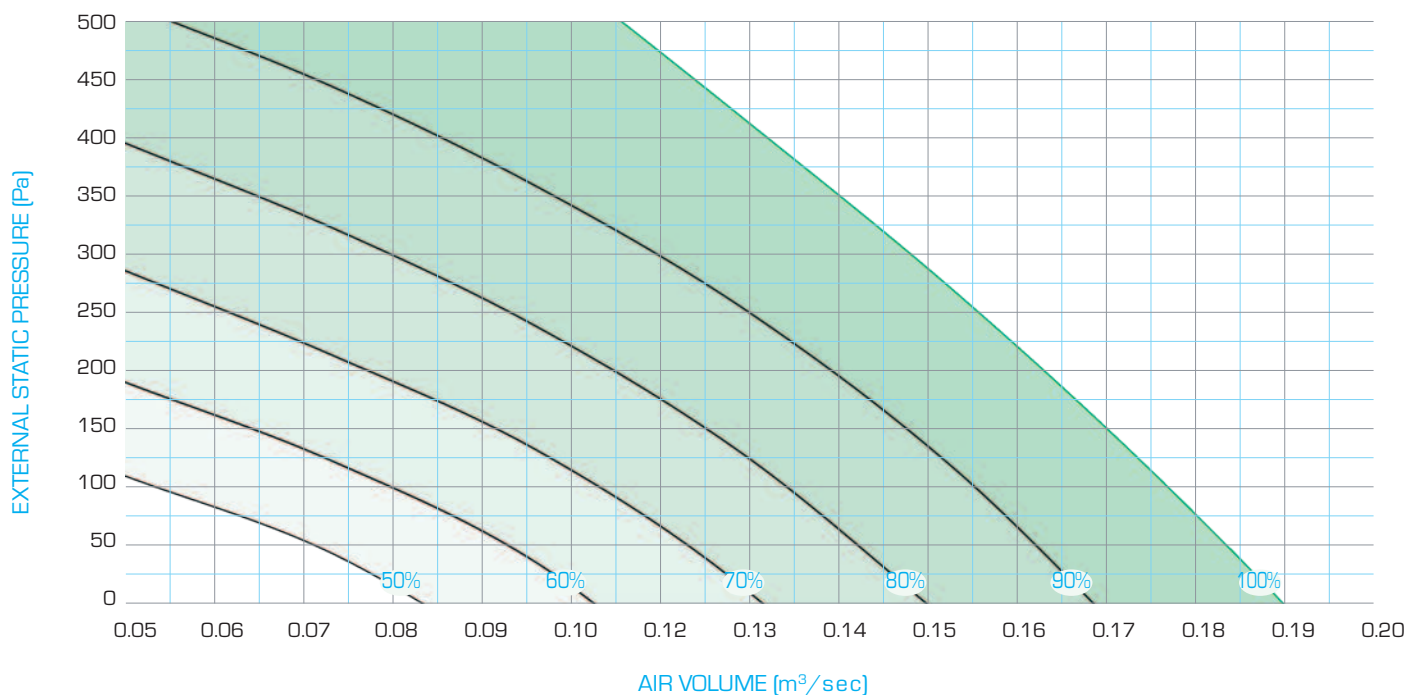

ELECTRICAL DATA per FAN

Maximum drawn current for UNIT - 6A
 (fuse/ circuit breaker rating does NOT include ancillaries)

MODEL	FAN POWER W	SUPPLY	FLC amps
HRPSL310EC	170	230V 1Ph	1.7

HRPSL310EC @ mid duty		Mid Octave Frequency band / Hz								Total in Duct		In Duct @ 1m		In Duct @ 3m		Breakout @ 1m		Breakout @ 3m	
		63	125	250	500	1k	2k	4k	8k	dB	dB(A)	dB	dB(A)	dB	dB(A)	dB(A)	NR	dB(A)	NR
0.095m³/s @100%	Inlet in duct dB	75	67	71	71	69	68	63	60	79	74	66	63	57	53	47	45	37	35
	Outlet in duct dB	77	68	72	77	75	76	68	64	83	81	73	53	63	61				
0.085m³/s @90%	Inlet in duct dB	73	67	70	68	67	65	60	57	77	72	64	60	54	50	46	44	36	34
	Outlet in duct dB	75	68	71	74	72	73	66	61	81	78	70	67	60	58				
0.075m³/s @80%	Inlet in duct dB	70	66	69	65	64	62	57	54	75	69	61	57	51	47	44	43	35	35
	Outlet in duct dB	71	67	71	70	69	69	63	58	78	75	66	64	57	54				
0.065m³/s @70%	Inlet in duct dB	65	64	66	62	61	59	54	50	71	66	58	54	48	44	42	41	33	31
	Outlet in duct dB	66	65	70	65	66	66	59	53	75	71	63	61	54	51				
0.055m³/s @60%	Inlet in duct dB	62	63	63	59	57	55	50	45	69	62	54	50	45	40	39	38	30	27
	Outlet in duct dB	61	63	66	62	62	62	55	49	71	67	59	57	50	47				
0.045m³/s @50%	Inlet in duct dB	61	61	58	56	53	51	45	39	66	59	50	46	41	36	35	32	25	22
	Outlet in duct dB	59	61	62	58	58	58	50	42	68	63	55	53	46	43				



TECHNICAL DATA - HRPSL310EC

SPECIFIC FAN POWER - FOR EACH FAN

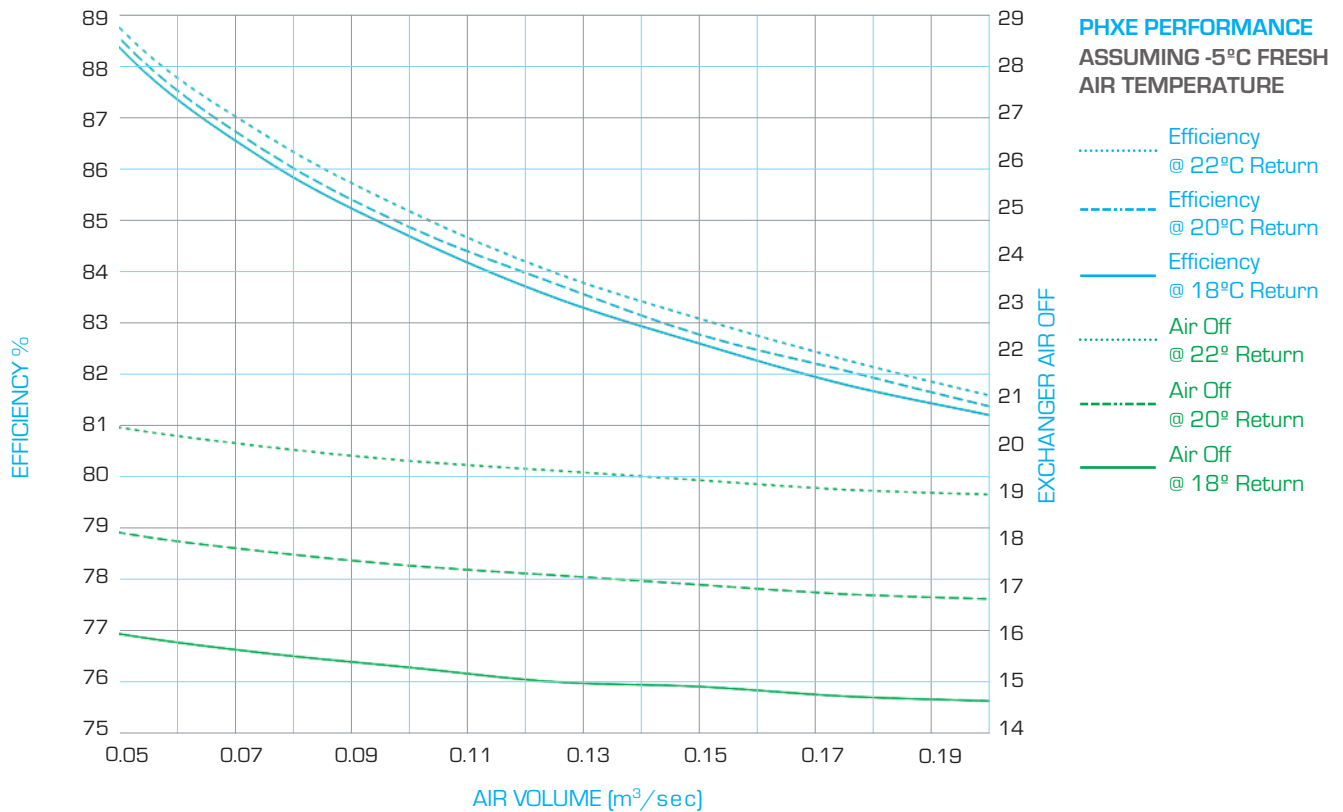
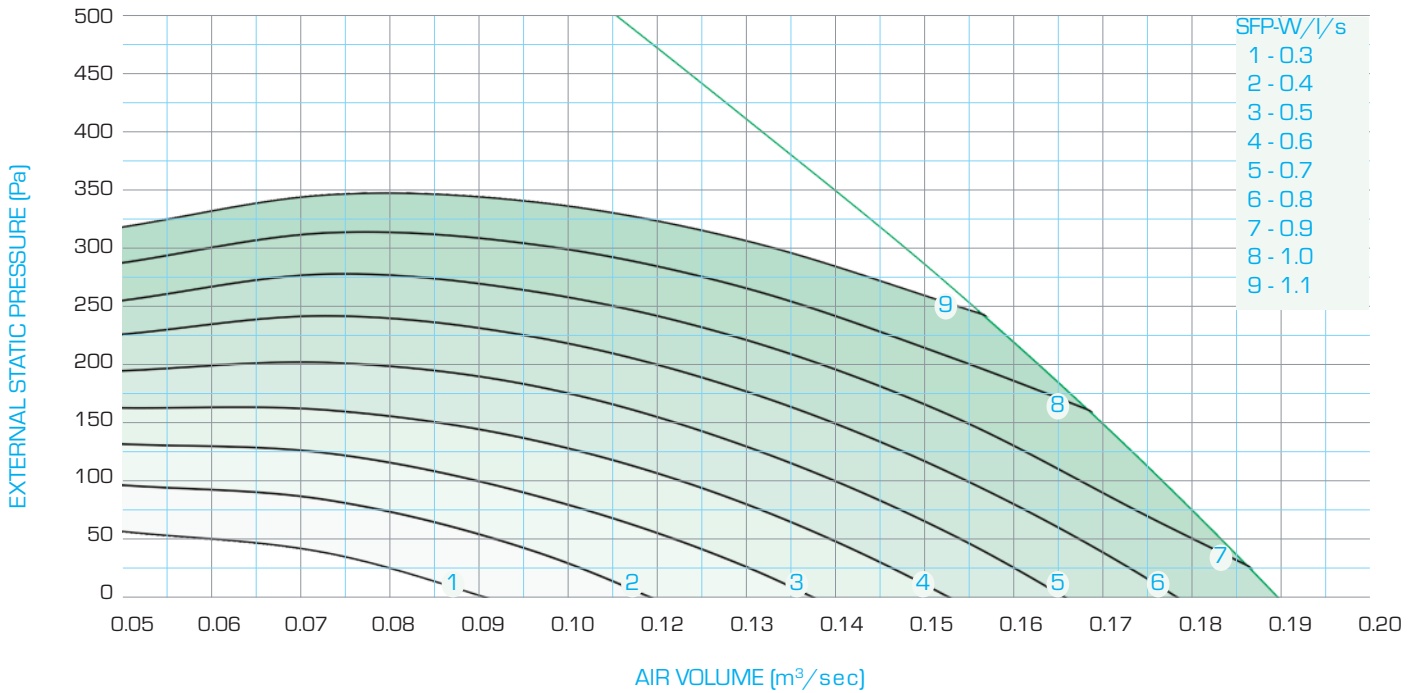



TECHNICAL DATA - HRPSL350EC

FAN SPEED

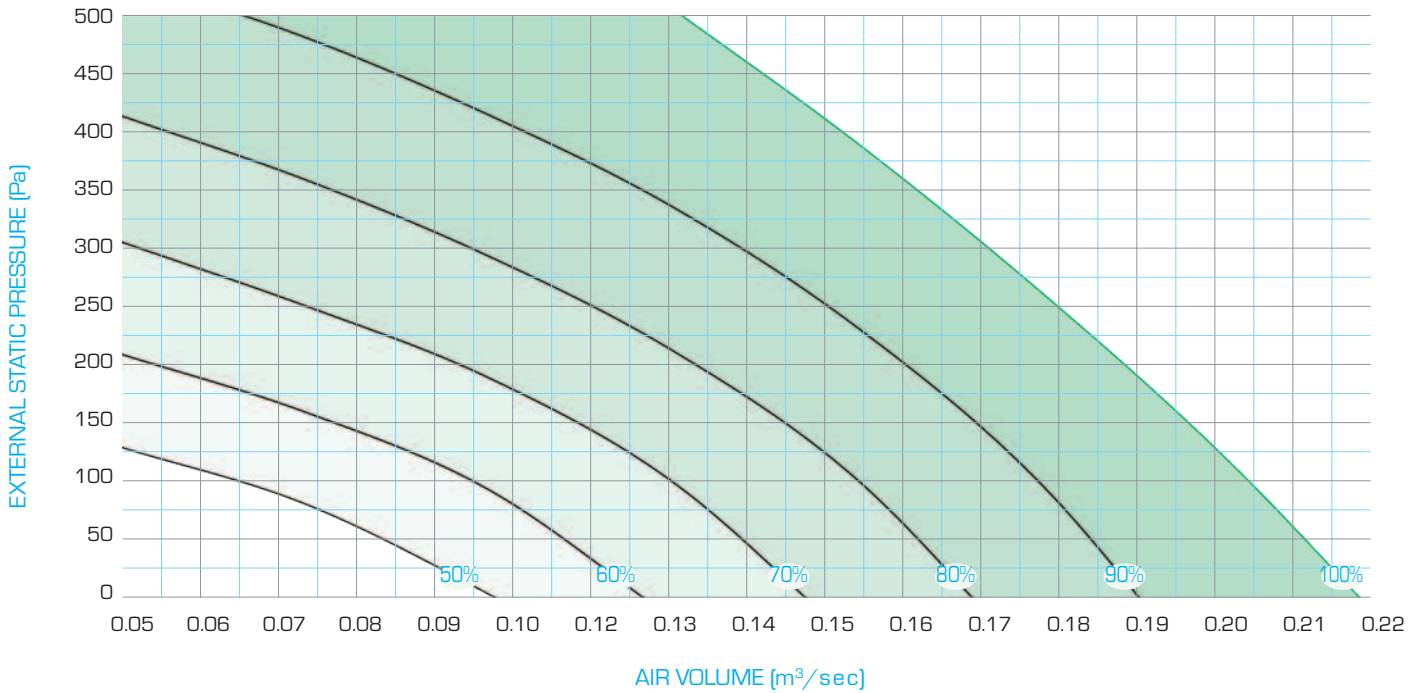

ELECTRICAL DATA per FAN
 Maximum drawn current for UNIT - 6A
 (fuse/ circuit breaker rating does NOT include ancillaries)

MODEL	FAN POWER W	SUPPLY	FLC amps
HRPSL350EC	170	230V 1Ph	1.7

HRPSL350EC @ mid duty		Mid Octave Frequency band / Hz								Total in Duct		In Duct @ 1m		In Duct @ 3m		Breakout @ 1m		Breakout @ 3m	
		63	125	250	500	1k	2k	4k	8k	dB	dB(A)	dB	dB(A)	dB	dB(A)	dB(A)	NR	dB(A)	NR
0.11m³/s @100%	Inlet in duct dB	77	67	70	70	68	68	63	61	80	74	66	63	56	53	47	44	37	34
	Outlet in duct dB	79	68	71	77	75	76	69	65	84	81	73	70	63	61				
0.095m³/s @90%	Inlet in duct dB	73	66	69	67	66	65	60	58	77	71	63	60	54	50	44	43	36	33
	Outlet in duct dB	75	67	70	74	72	72	66	61	80	77	69	67	60	57				
0.085m³/s @80%	Inlet in duct dB	70	64	66	64	63	62	57	54	74	68	60	57	51	47	43	41	33	31
	Outlet in duct dB	67	64	69	70	69	69	63	58	76	74	66	64	57	54				
0.070m³/s @70%	Inlet in duct dB	65	63	66	61	61	59	54	50	71	66	58	54	48	44	42	41	32	31
	Outlet in duct dB	66	64	69	65	66	66	59	54	74	71	63	61	54	51				
0.060m³/s @60%	Inlet in duct dB	61	61	62	59	57	55	50	46	68	62	54	50	45	40	38	37	29	26
	Outlet in duct dB	60	62	66	62	62	62	56	49	71	67	59	57	50	47				
0.050m³/s @50%	Inlet in duct dB	59	59	57	55	52	51	46	40	64	58	50	46	40	36	34	31	24	21
	Outlet in duct dB	58	60	61	58	57	58	51	43	67	63	55	53	45	43				



TECHNICAL DATA - HRPSL350EC

SPECIFIC FAN POWER - FOR EACH FAN

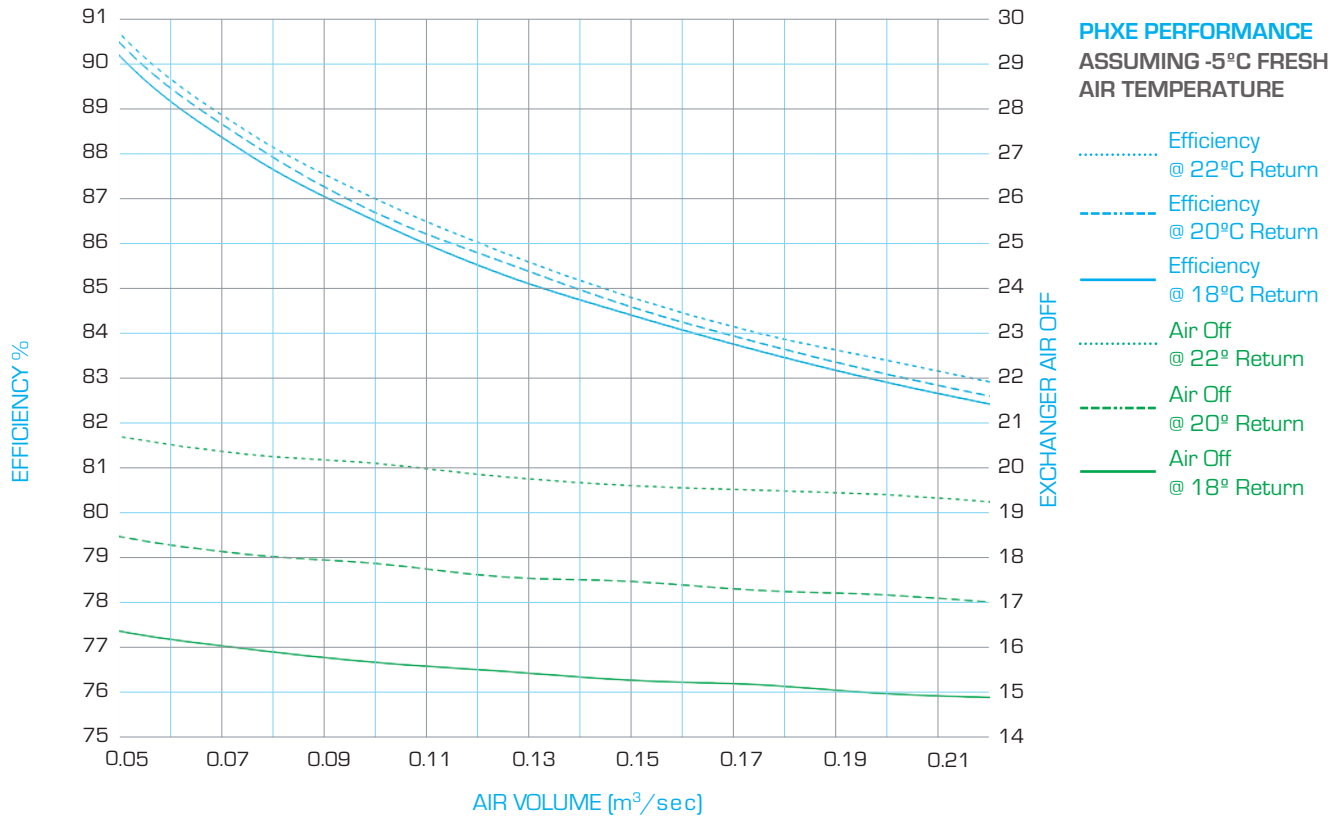
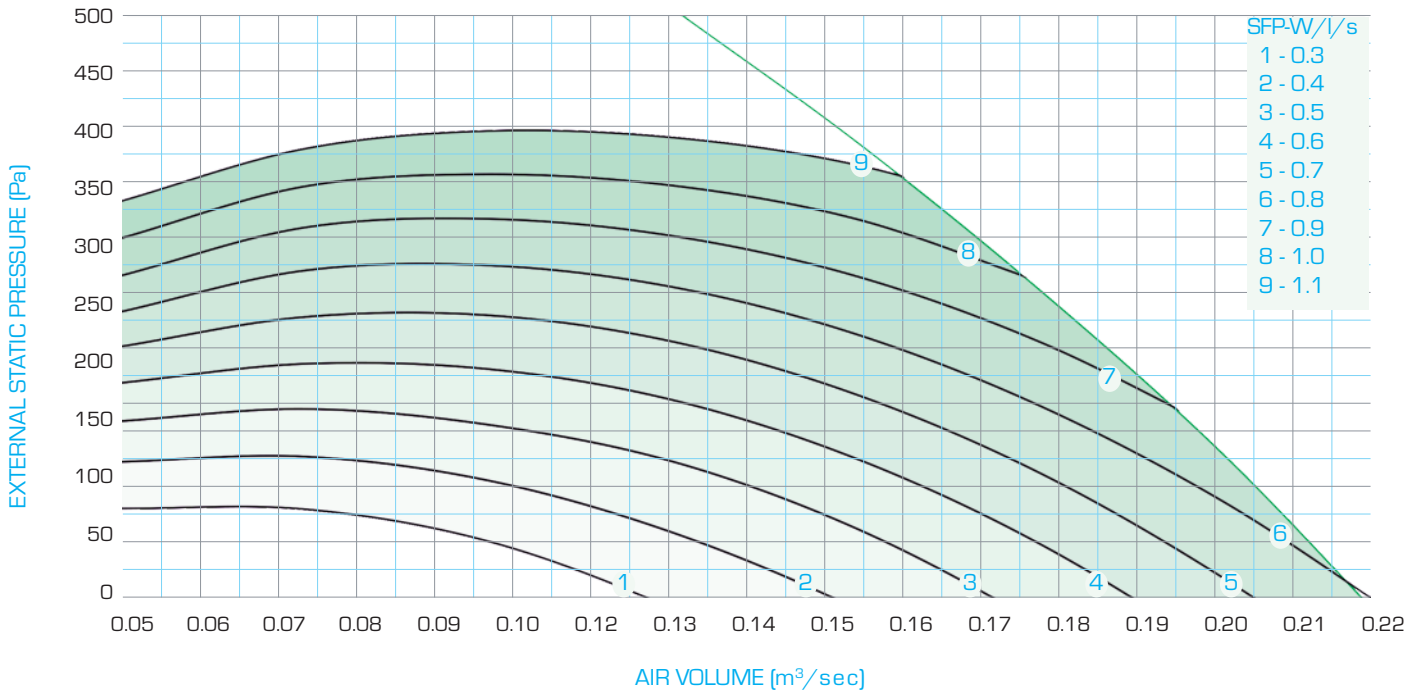



TECHNICAL DATA - HRPSL390EC

FAN SPEED

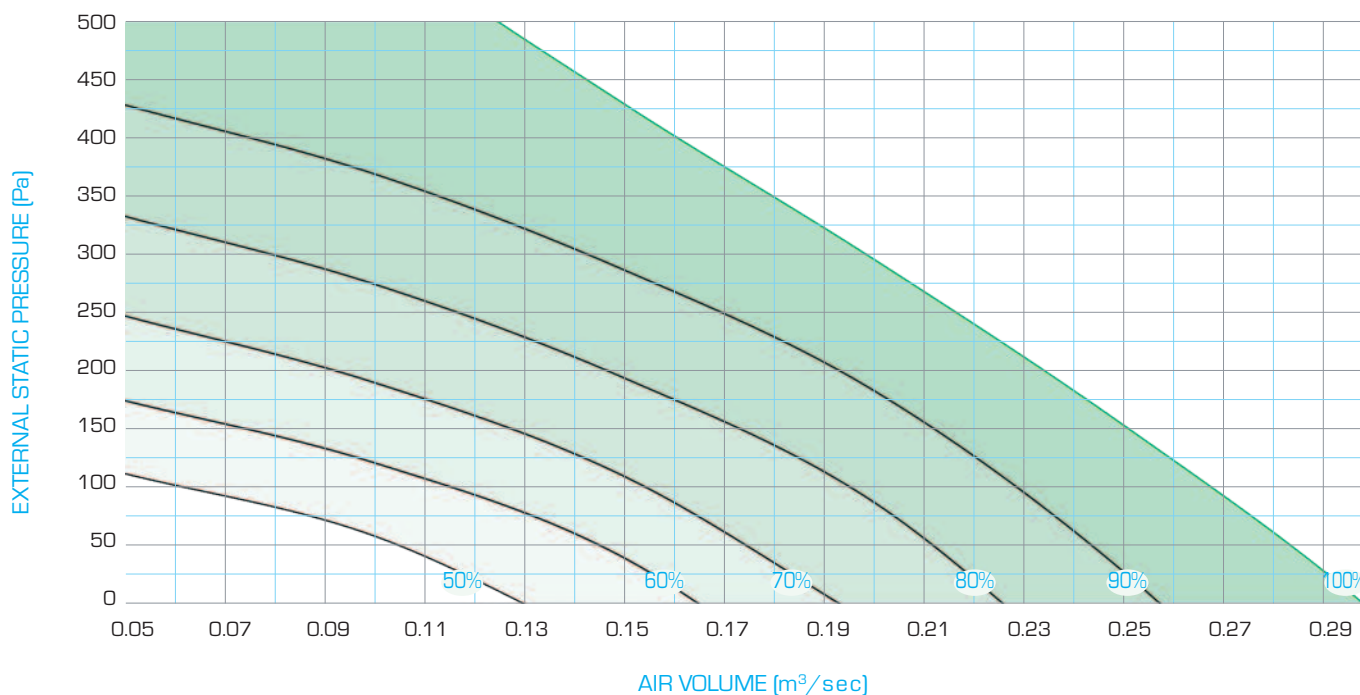

ELECTRICAL DATA per FAN

Maximum drawn current for UNIT - 6A
(fuse/ circuit breaker rating does NOT include ancillaries)

MODEL	FAN POWER W	SUPPLY	FLC amps
HRPSL390EC	170	230V 1Ph	1.75

HRPSL390EC @ mid duty		Mid Octave Frequency band / Hz								Total in Duct		In Duct @ 1m		In Duct @ 3m		Breakout @ 1m		Breakout @ 3m	
		63	125	250	500	1k	2k	4k	8k	dB	dB(A)	dB	dB(A)	dB	dB(A)	dB(A)	NR	dB(A)	NR
0.15m³/s @100%	Inlet in duct dB	65	65	67	66	63	59	57	53	73	68	60	55	51	45	43	41	33	31
	Outlet in duct dB	66	66	69	69	67	66	61	57	75	72	64	61	55	51				
0.13m³/s @90%	Inlet in duct dB	63	64	65	64	60	56	54	49	71	66	58	53	48	43	41	39	31	28
	Outlet in duct dB	63	65	67	67	64	64	58	54	73	70	62	59	52	49				
0.115m³/s @80%	Inlet in duct dB	63	63	63	61	57	53	51	46	69	63	55	49	45	40	39	37	29	26
	Outlet in duct dB	61	64	65	64	61	61	55	50	71	67	59	56	49	46				
0.095m³/s @70%	Inlet in duct dB	61	63	61	58	54	51	48	41	67	60	52	46	42	37	37	34	28	24
	Outlet in duct dB	60	64	62	60	58	59	52	46	69	64	56	54	47	44				
0.085m³/s @60%	Inlet in duct dB	59	60	57	53	50	46	43	36	64	56	47	42	38	32	33	30	24	20
	Outlet in duct dB	57	60	58	55	54	54	47	41	65	60	51	49	42	39				
0.065m³/s @50%	Inlet in duct dB	57	58	54	49	47	43	38	30	62	52	44	39	34	29	33	30	24	20
	Outlet in duct dB	56	58	55	50	51	50	43	34	62	56	48	45	38	35				

Heat Recovery Units - EC Motors



TECHNICAL DATA - HRP3L390EC

SPECIFIC FAN POWER - FOR EACH FAN

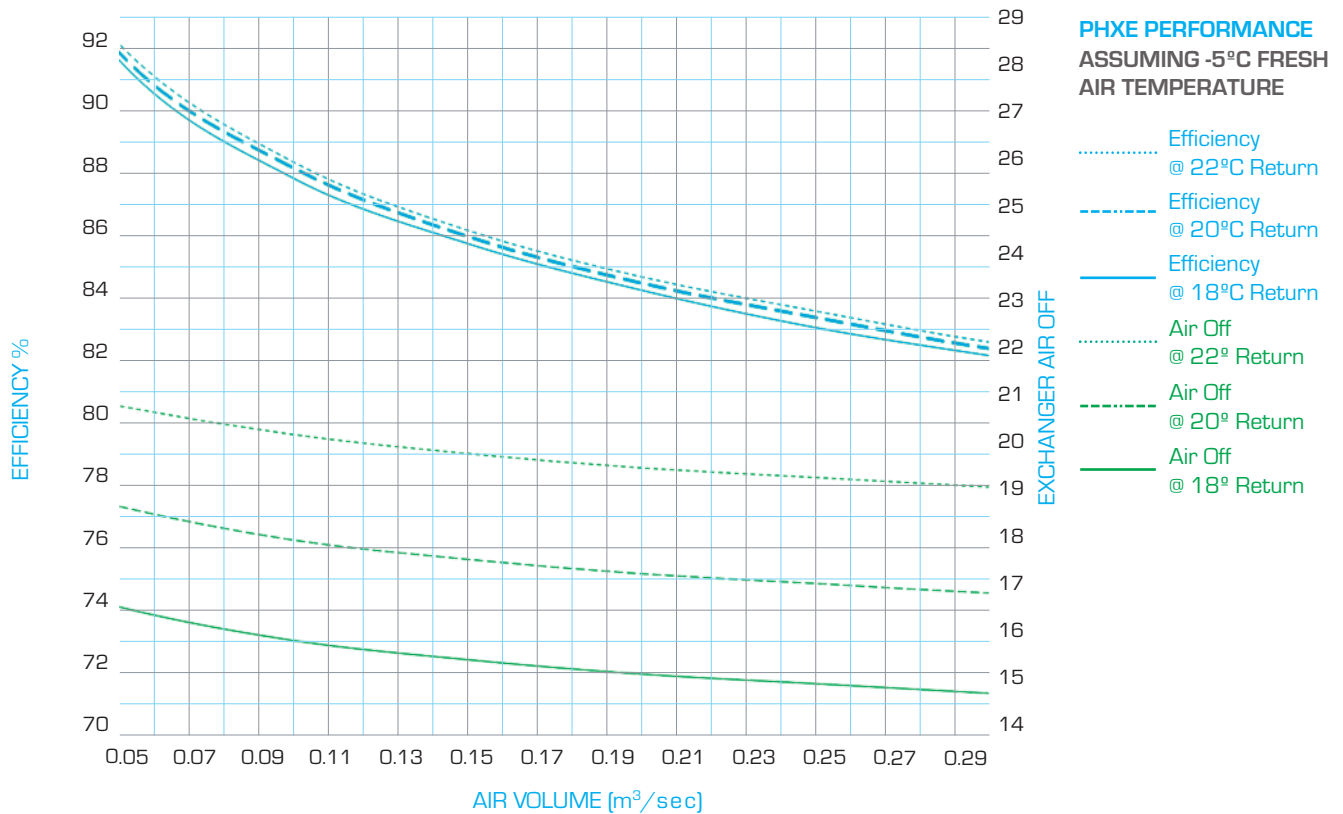
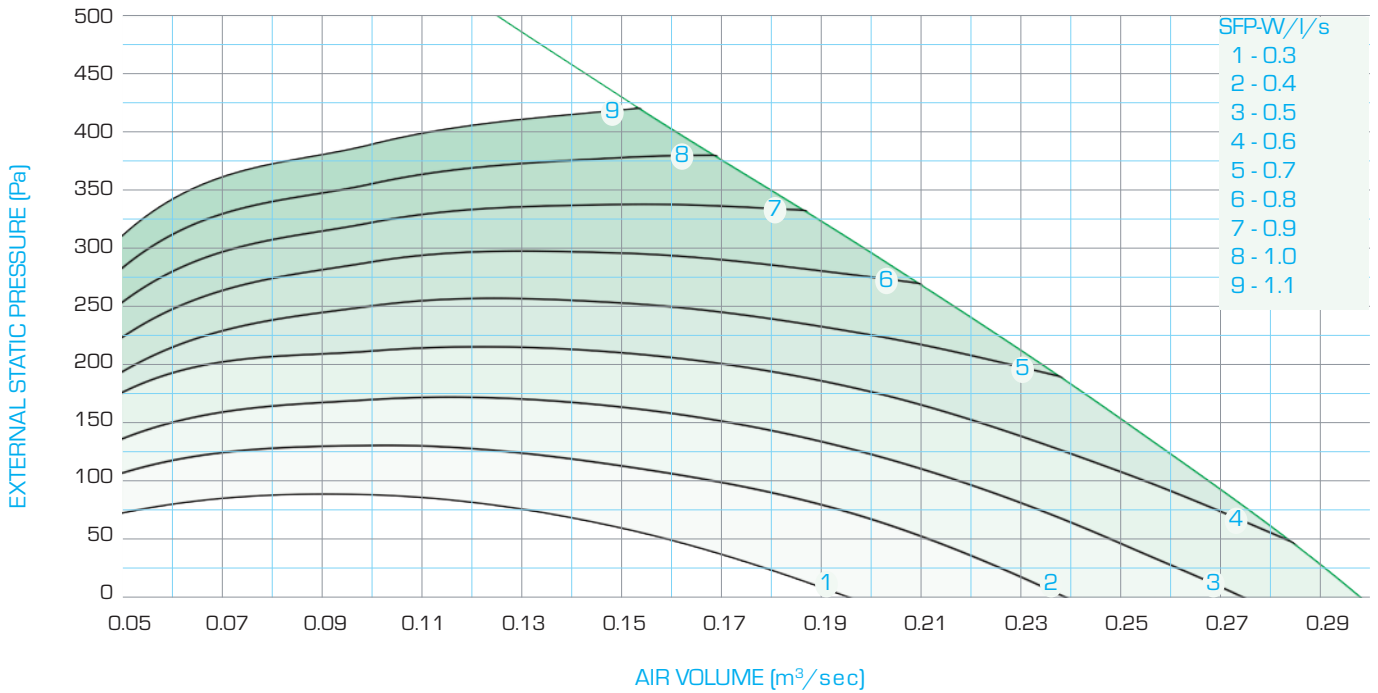



TECHNICAL DATA - HRPSL470EC

FAN SPEED

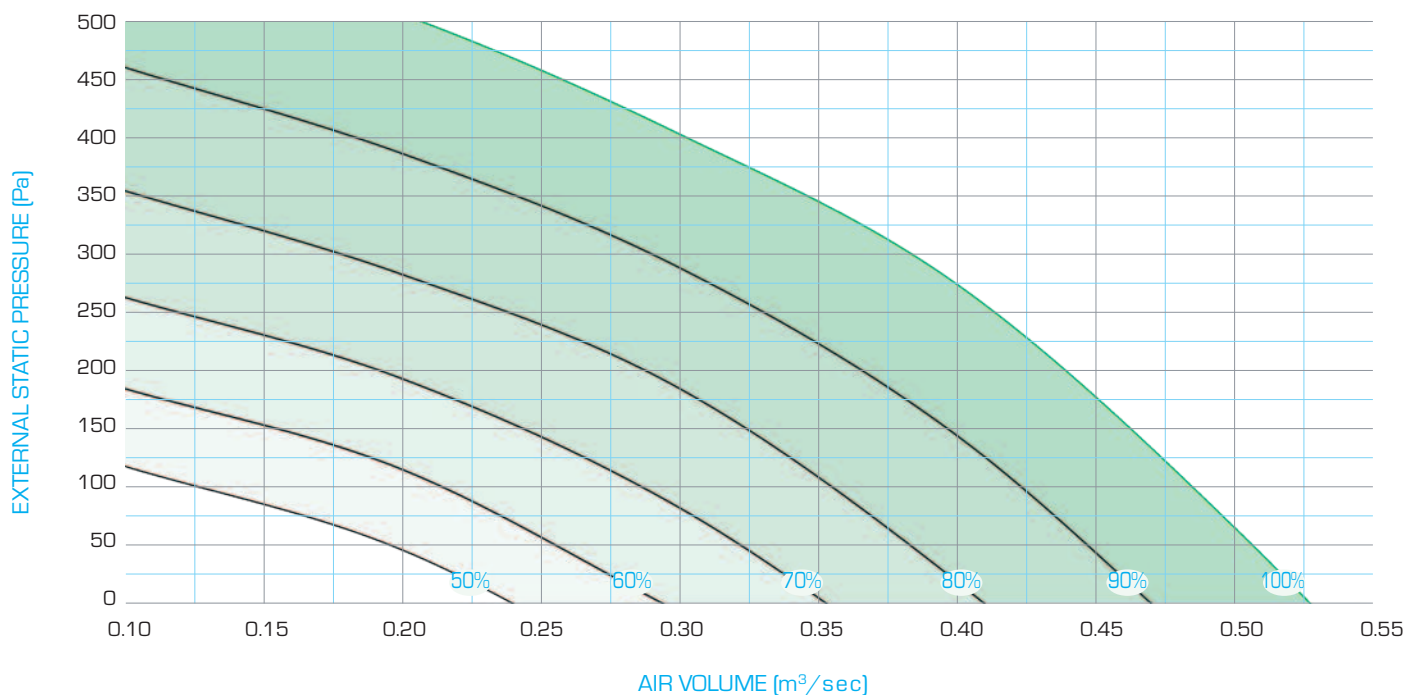

ELECTRICAL DATA per FAN

Maximum drawn current for UNIT - 6A
(fuse/ circuit breaker rating does NOT include ancillaries)

MODEL	FAN POWER W	SUPPLY	FLC amps
HRPSL470EC	360	230V 1Ph	1.80

HRPSL470EC @ mid duty		Mid Octave Frequency band / Hz								Total in Duct		In Duct @ 1m		In Duct @ 3m		Breakout @ 1m		Breakout @ 3m	
		63	125	250	500	1k	2k	4k	8k	dB	dB(A)	dB	dB(A)	dB	dB(A)	dB(A)	NR	dB(A)	NR
0.265m³/s @100%	Inlet in duct dB	81	76	76	74	67	61	56	54	84	74	66	63	56	53	53	52	43	41
	Outlet in duct dB	79	78	79	77	72	68	62	58	85	78	70	66	60	56				
0.235m³/s @90%	Inlet in duct dB	79	75	72	69	63	58	53	51	81	70	62	58	52	48	49	47	40	37
	Outlet in duct dB	78	77	75	73	69	65	59	54	82	75	66	62	57	52				
0.205m³/s @80%	Inlet in duct dB	77	73	69	65	59	55	50	48	79	67	58	54	49	44	47	44	37	34
	Outlet in duct dB	76	75	72	69	65	62	55	50	80	71	63	58	53	48				
0.175m³/s @70%	Inlet in duct dB	74	73	66	62	56	52	46	43	77	64	55	54	46	41	45	41	35	31
	Outlet in duct dB	73	74	69	65	62	58	51	45	78	68	59	56	50	44				
0.150m³/s @60%	Inlet in duct dB	71	70	61	58	53	47	42	35	74	60	51	46	42	37	41	37	31	26
	Outlet in duct dB	70	70	64	60	58	53	46	38	74	63	55	50	45	40				
0.120m³/s @50%	Inlet in duct dB	68	65	56	53	48	42	37	30	70	55	46	41	37	31	36	31	26	20
	Outlet in duct dB	67	65	59	55	53	48	39	32	70	58	50	45	40	35				

Heat Recovery Units - EC Motors



TECHNICAL DATA - HRPSL470EC

SPECIFIC FAN POWER - FOR EACH FAN

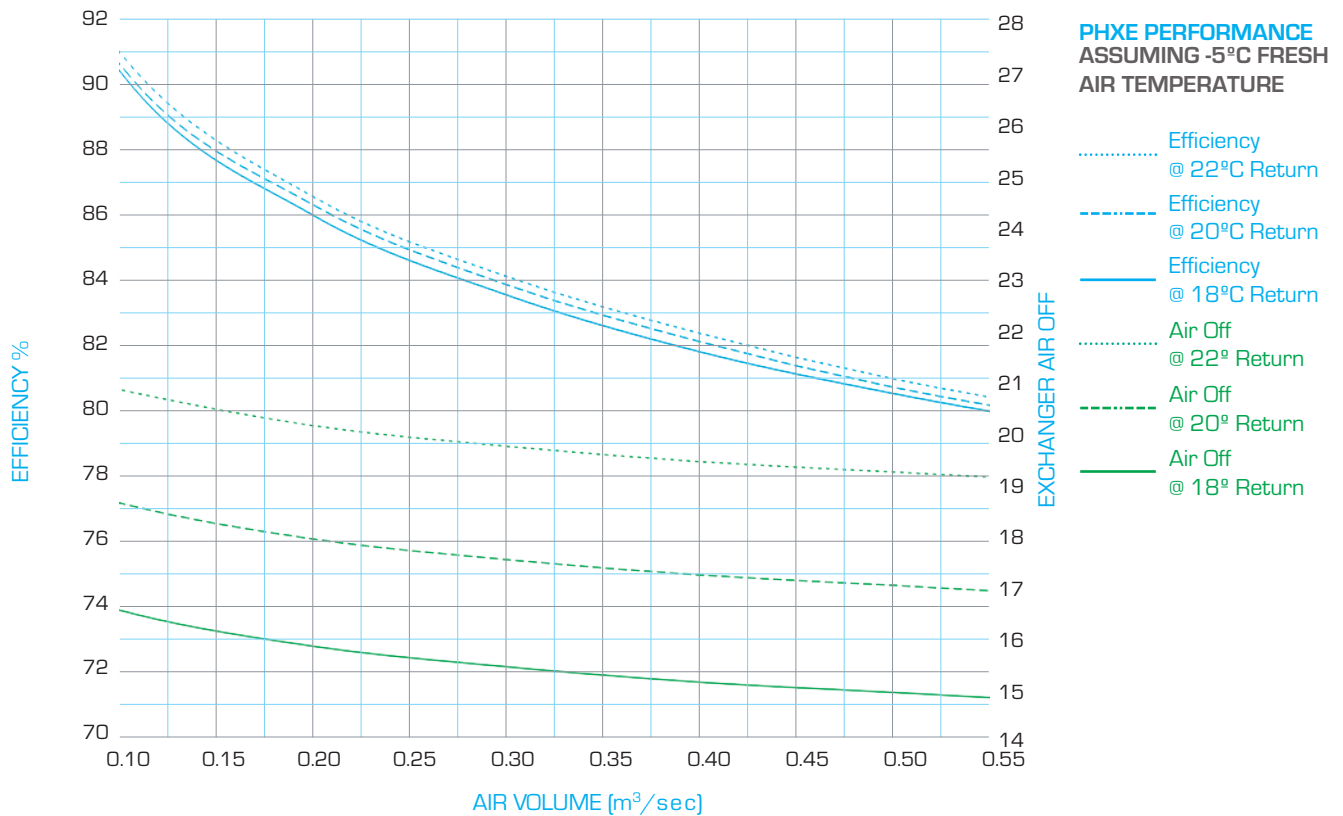
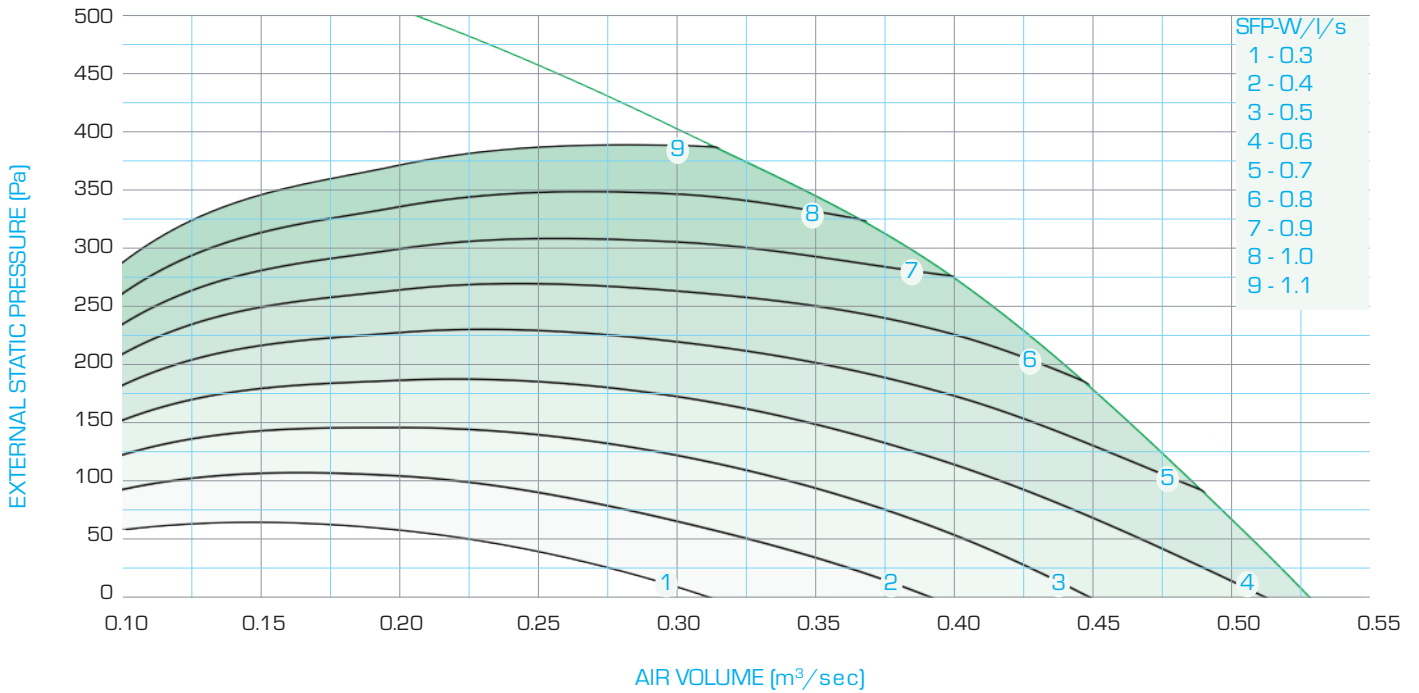



TECHNICAL DATA - HRPSL560EC

FAN SPEED

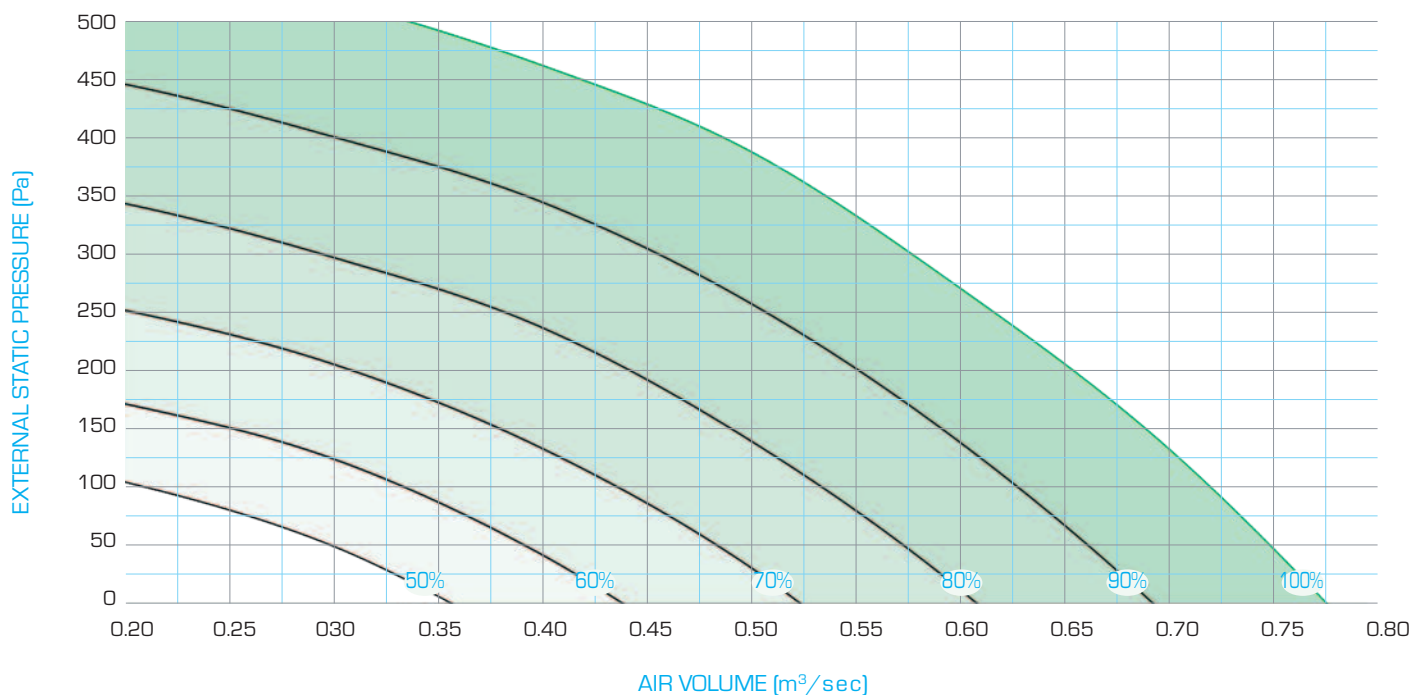

ELECTRICAL DATA per FAN

Maximum drawn current for UNIT - 10A
(fuse/ circuit breaker rating does NOT include ancillaries)

MODEL	FAN POWER W	SUPPLY	FLC amps
HRPSL560EC	480	230V 1Ph	2.40

HRPSL560EC @ mid duty		Mid Octave Frequency band / Hz								Total in Duct		In Duct @ 1m		In Duct @ 3m		Breakout @ 1m		Breakout @ 3m	
		63	125	250	500	1k	2k	4k	8k	dB	dB(A)	dB	dB(A)	dB	dB(A)	dB(A)	NR	dB(A)	NR
0.390m³/s @100%	Inlet in duct dB	76	71	74	69	63	64	61	54	80	72	64	59	54	49	54	54	41	40
	Outlet in duct dB	78	75	79	72	72	71	65	60	83	77	69	66	60	56				
0.350m³/s @90%	Inlet in duct dB	75	72	69	66	61	61	58	51	78	69	60	56	51	46	47	45	38	35
	Outlet in duct dB	76	75	74	69	70	68	62	57	81	75	66	63	57	53				
0.305m³/s @80%	Inlet in duct dB	74	70	64	63	58	58	55	47	76	65	57	53	48	43	44	40	34	30
	Outlet in duct dB	74	74	69	66	67	65	58	53	79	71	63	60	54	50				
0.265m³/s @70%	Inlet in duct dB	71	69	60	59	55	54	50	42	74	62	53	49	44	39	41	38	32	27
	Outlet in duct dB	72	72	64	63	64	61	54	47	76	68	60	56	50	46				
0.220m³/s @60%	Inlet in duct dB	67	67	57	56	52	50	46	36	71	59	50	45	40	35	38	35	29	24
	Outlet in duct dB	67	69	60	59	61	57	49	41	72	64	56	53	47	43				
0.180m³/s @50%	Inlet in duct dB	65	62	52	51	48	45	40	30	67	54	45	40	36	31	33	29	24	18
	Outlet in duct dB	65	64	56	55	56	52	43	35	68	60	51	48	42	38				



TECHNICAL DATA - HRPSL560EC

SPECIFIC FAN POWER - FOR EACH FAN

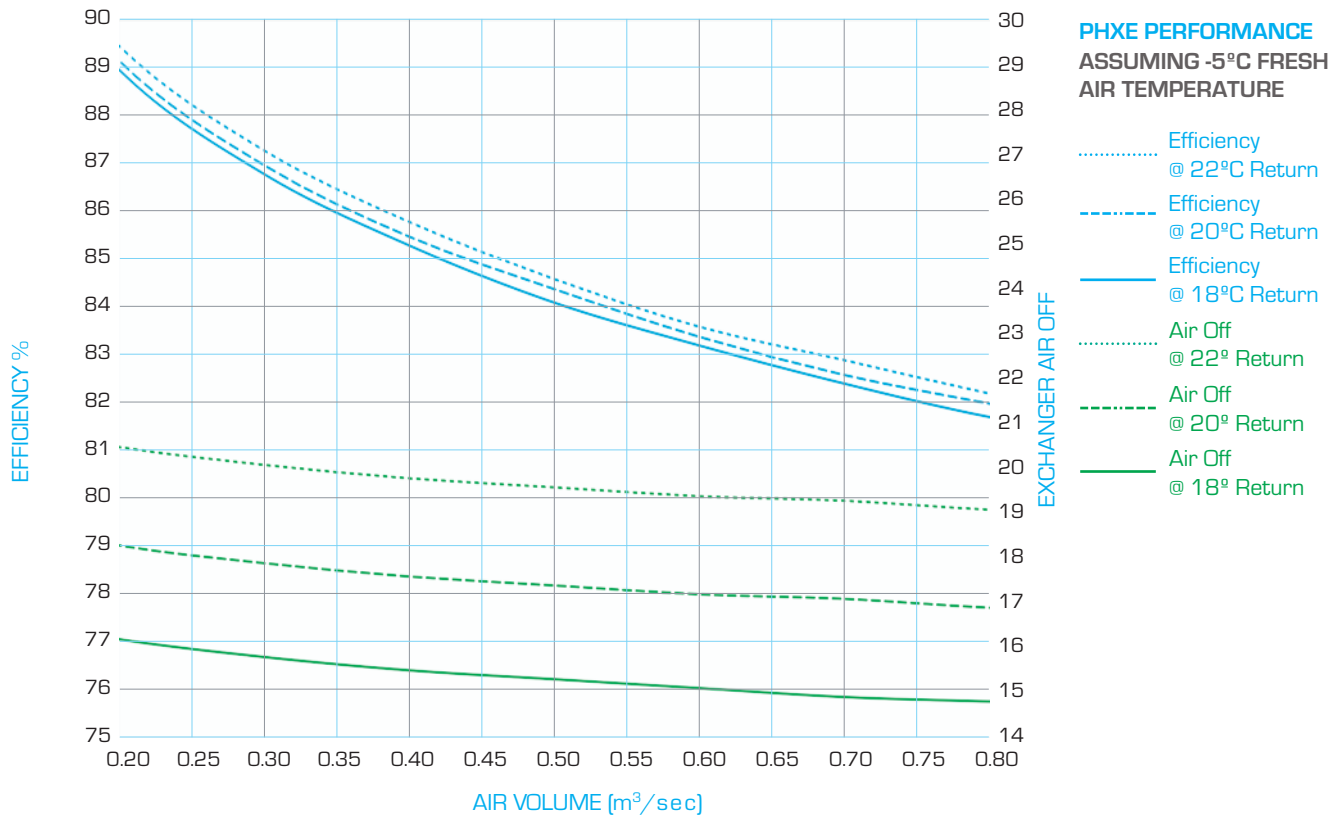
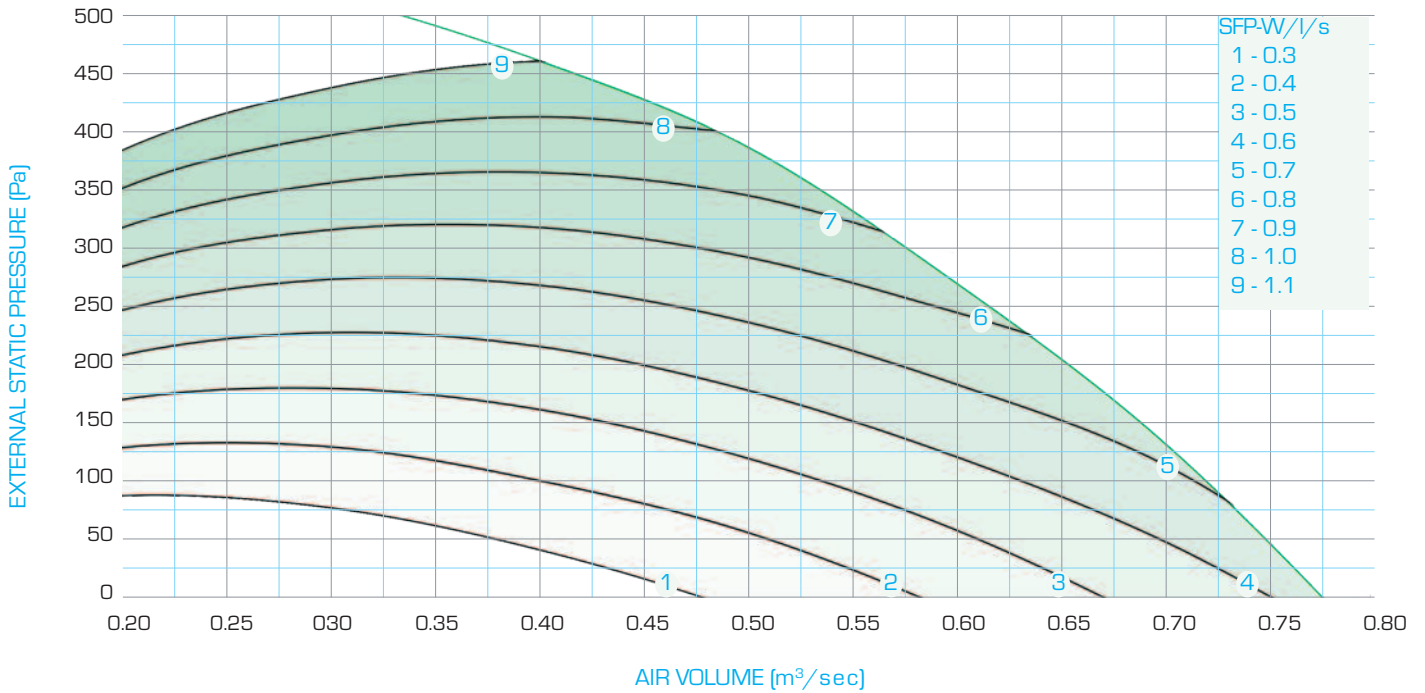



TECHNICAL DATA - HRPSL650EC

FAN SPEED

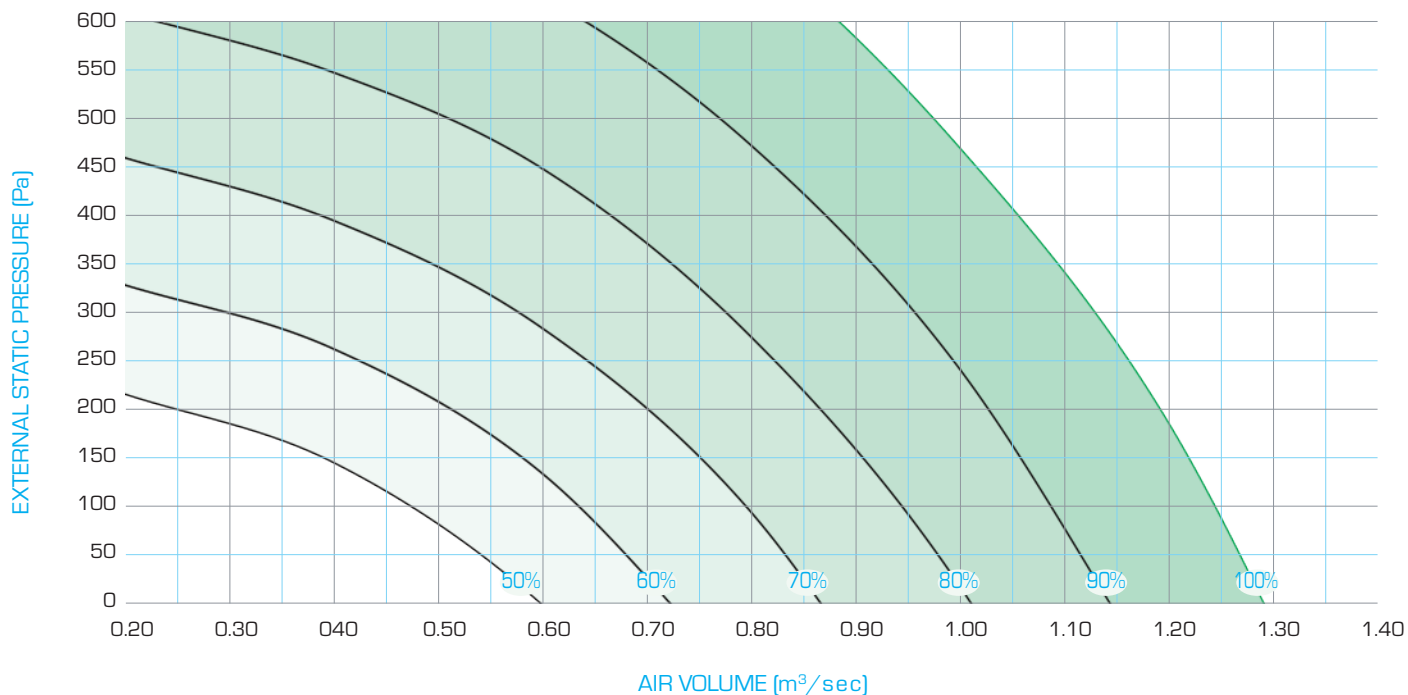

ELECTRICAL DATA per FAN

Maximum drawn current for UNIT - 16A
(fuse/circuit breaker rating does NOT include ancillaries)

MODEL	FAN POWER W	SUPPLY	FLC amps
HRPSL650EC	1350	230V 1Ph	6.80

HRPSL650EC @ mid duty		Mid Octave Frequency band / Hz								Total in Duct		In Duct @ 1m		In Duct @ 3m		Breakout @ 1m		Breakout @ 3m	
		63	125	250	500	1k	2k	4k	8k	dB	dB(A)	dB	dB(A)	dB	dB(A)	dB(A)	NR	dB(A)	NR
0.650m³/s @100%	Inlet in duct dB	80	76	80	75	68	69	66	62	85	77	69	65	60	54	58	58	48	48
	Outlet in duct dB	82	80	86	79	80	77	73	68	90	85	77	72	67	62				
0.575m³/s @90%	Inlet in duct dB	79	75	77	72	66	66	63	58	83	74	66	61	57	51	54	54	44	44
	Outlet in duct dB	81	79	82	76	77	74	70	65	87	81	73	69	64	59				
0.510m³/s @80%	Inlet in duct dB	76	74	73	69	63	63	60	55	80	71	63	58	53	48	51	50	41	39
	Outlet in duct dB	78	77	78	73	74	70	66	61	84	78	70	48	60	56				
0.435m³/s @70%	Inlet in duct dB	73	73	67	65	60	59	56	50	77	67	59	54	49	44	47	43	37	33
	Outlet in duct dB	74	76	72	70	71	67	62	57	80	75	67	63	57	53				
0.365m³/s @60%	Inlet in duct dB	71	72	63	61	57	56	52	45	75	64	55	51	46	41	43	40	34	29
	Outlet in duct dB	72	74	67	66	68	63	58	51	78	71	63	60	53	50				
0.300m³/s @50%	Inlet in duct dB	68	69	58	57	53	51	46	38	72	60	51	46	41	36	39	36	30	25
	Outlet in duct dB	68	69	62	61	63	58	52	44	73	66	58	55	48	45				



TECHNICAL DATA - HRPSL650EC

SPECIFIC FAN POWER - FOR EACH FAN

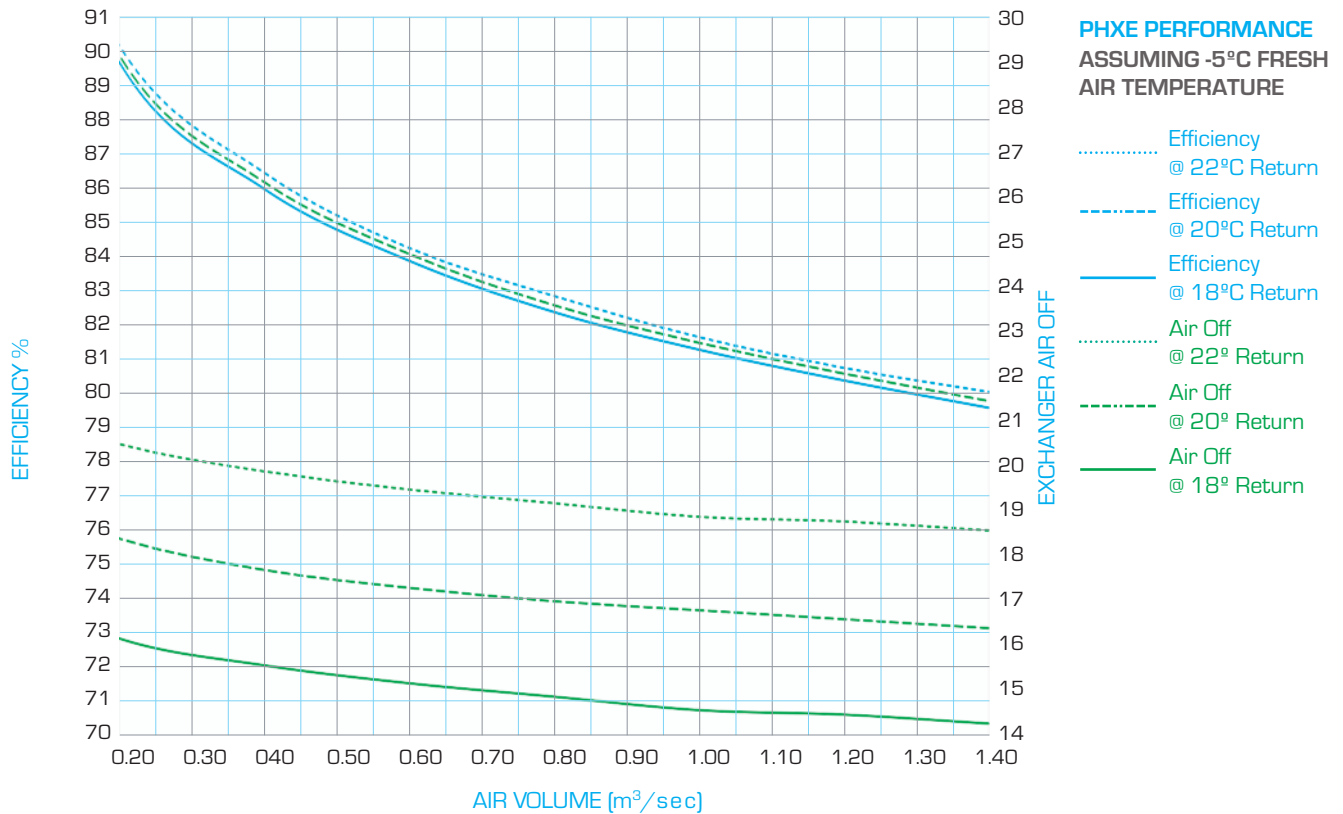
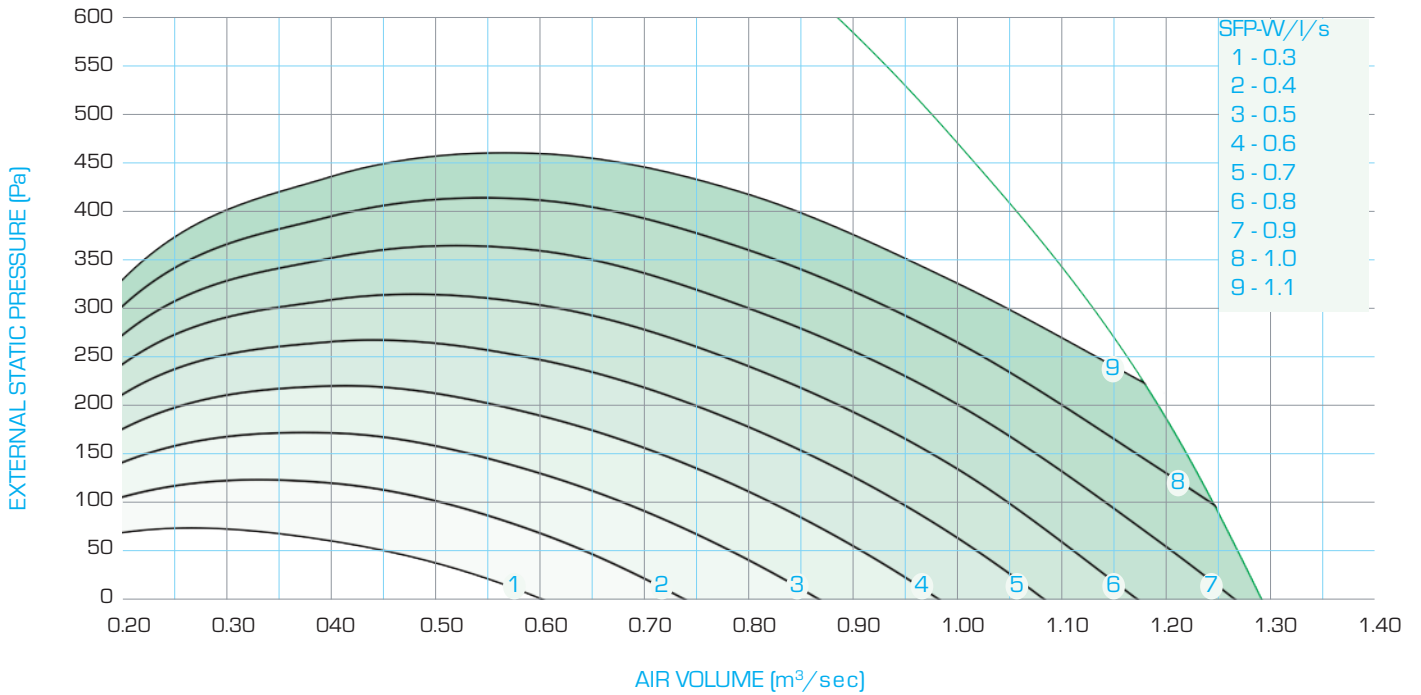



TECHNICAL DATA - HRPSL800EC

FAN SPEED

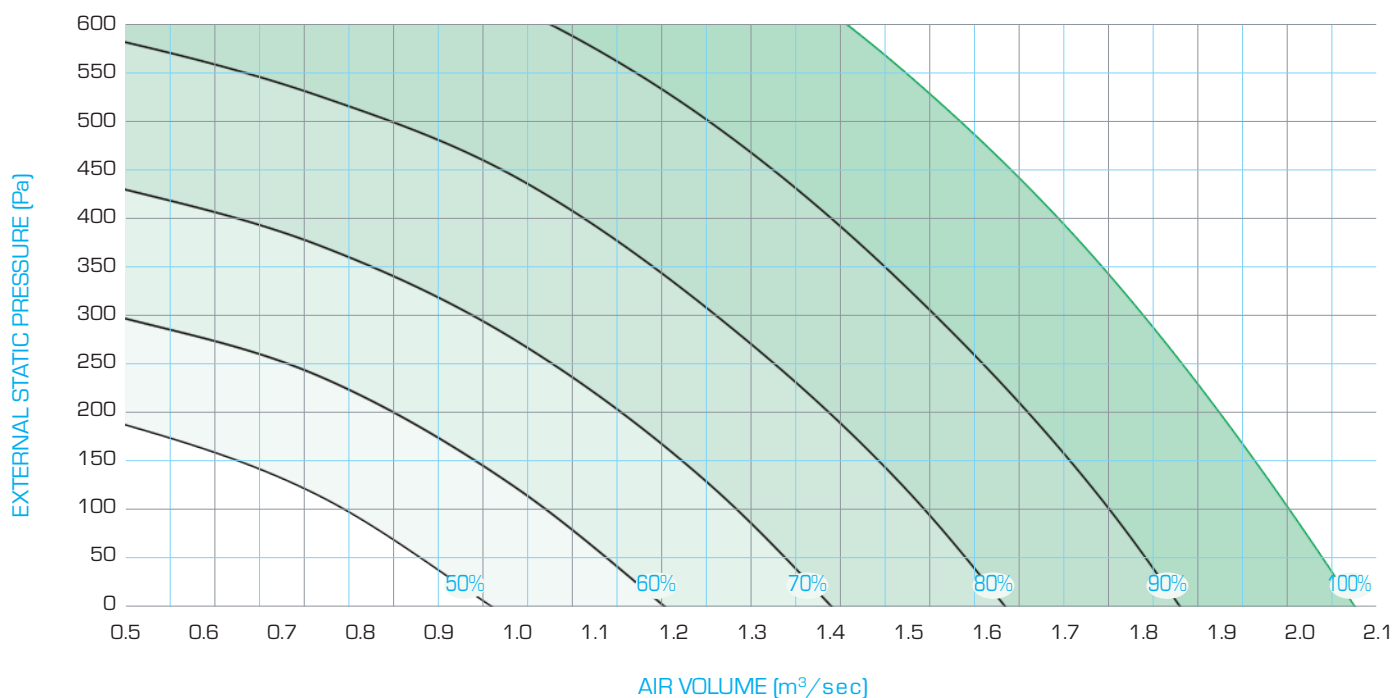

ELECTRICAL DATA per FAN

Maximum drawn current for UNIT - 32A
(fuse/ circuit breaker rating does NOT include ancillaries)

MODEL	FAN POWER W	SUPPLY	FLC amps
HRPSL800EC	2000	400V 3Ph	3.30

HRPSL800EC @ mid duty		Mid Octave Frequency band / Hz								Total in Duct		In Duct @ 1m		In Duct @ 3m		Breakout @ 1m		Breakout @ 3m	
		63	125	250	500	1k	2k	4k	8k	dB	dB(A)	dB	dB(A)	dB	dB(A)	dB(A)	NR	dB(A)	NR
1.040m³/s @100%	Inlet in duct dB	82	79	79	75	69	70	66	61	86	77	69	65	60	55	57	56	48	46
	Outlet in duct dB	85	86	84	80	79	76	72	66	91	84	76	71	66	61				
0.930m³/s @90%	Inlet in duct dB	79	79	76	73	68	67	63	58	84	75	67	62	57	52	54	52	45	41
	Outlet in duct dB	82	84	80	78	77	74	69	63	88	82	73	69	64	59				
0.815m³/s @80%	Inlet in duct dB	77	78	73	70	66	64	60	53	82	73	64	59	55	49	51	48	42	38
	Outlet in duct dB	79	81	76	74	75	71	66	60	85	79	71	67	61	57				
0.705m³/s @70%	Inlet in duct dB	75	76	69	66	62	61	56	49	79	69	60	56	51	46	48	45	39	34
	Outlet in duct dB	76	78	73	71	71	67	62	56	82	75	67	63	57	53				
0.565m³/s @60%	Inlet in duct dB	74	73	66	63	58	57	52	44	77	65	57	52	47	42	45	41	36	31
	Outlet in duct dB	75	75	69	68	68	63	57	50	79	72	63	60	54	50				
0.490m³/s @50%	Inlet in duct dB	70	67	61	57	55	53	46	38	72	61	52	48	43	38	40	36	30	25
	Outlet in duct dB	71	68	65	63	63	58	51	43	74	67	58	55	49	45				



TECHNICAL DATA - HRPSL800EC

SPECIFIC FAN POWER - FOR EACH FAN

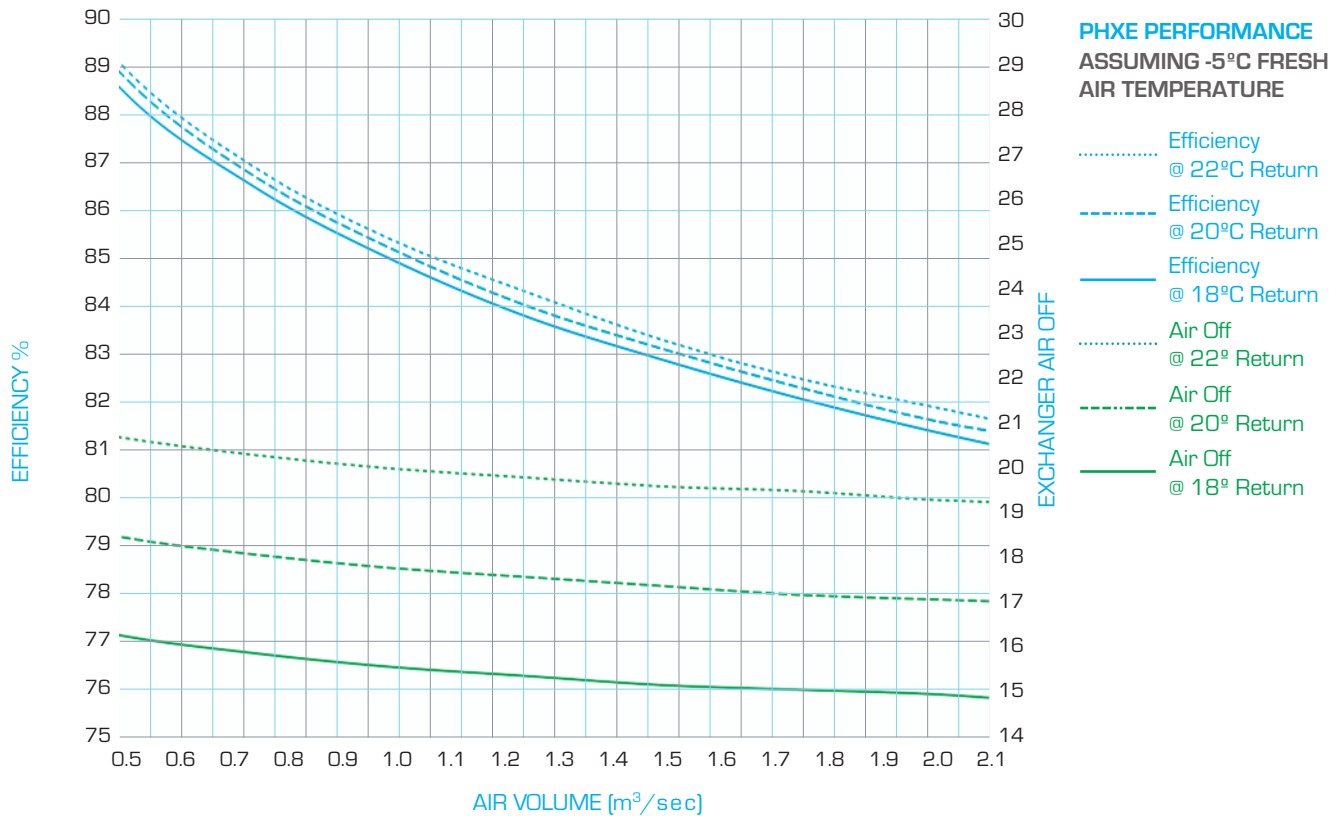
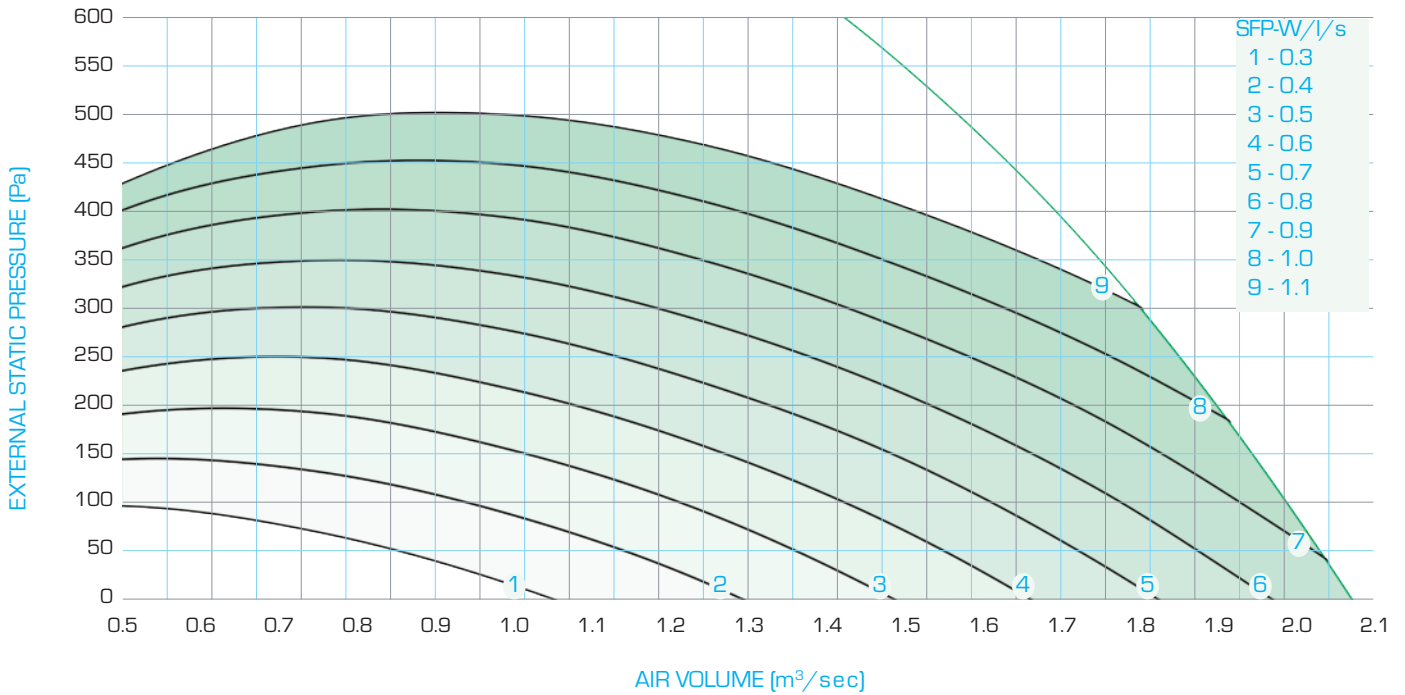



TECHNICAL DATA - HRPSL950EC

FAN SPEED

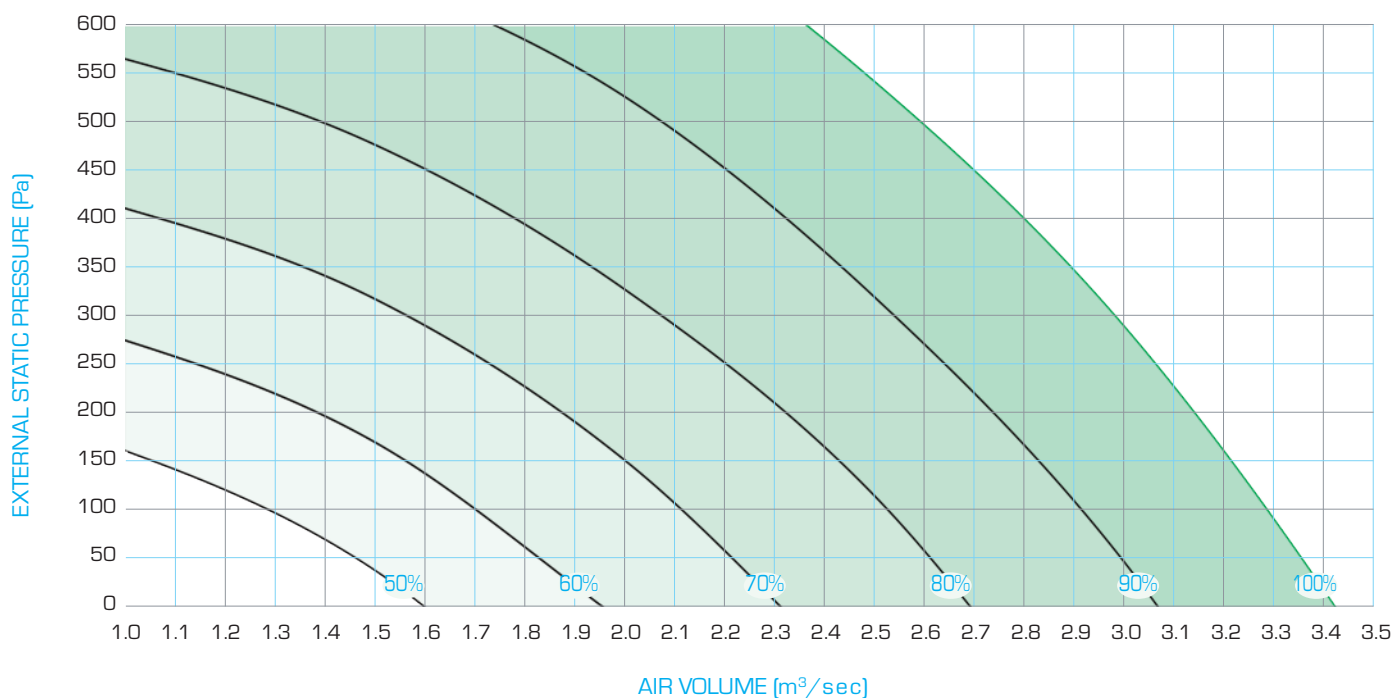

ELECTRICAL DATA per FAN Maximum drawn current for UNIT - 40A (fuse/circuit breaker rating does NOT include ancillaries)	MODEL	FAN POWER W	SUPPLY	FLC amps
	HRPSL950EC	3400	400V 3Ph	5.60

HRPSL950EC @ mid duty		Mid Octave Frequency band / Hz								Total in Duct		In Duct @ 1m		In Duct @ 3m		Breakout @ 1m		Breakout @ 3m	
		63	125	250	500	1k	2k	4k	8k	dB	dB(A)	dB	dB(A)	dB	dB(A)	dB(A)	NR	dB(A)	NR
1.71m³/s @100%	Inlet in duct dB	82	86	82	77	73	73	69	63	89	80	72	67	63	58	60	59	51	49
	Outlet in duct dB	86	90	87	83	81	78	75	69	94	86	78	73	69	63				
1.54m³/s @90%	Inlet in duct dB	82	85	78	72	70	70	66	60	88	77	69	65	59	55	58	56	48	45
	Outlet in duct dB	84	88	83	80	78	75	71	65	91	83	75	70	68	60				
1.35m³/s @80%	Inlet in duct dB	80	82	75	69	67	67	63	56	85	74	66	62	56	52	55	53	45	42
	Outlet in duct dB	82	85	80	77	75	72	68	62	88	80	72	67	62	57				
1.16m³/s @70%	Inlet in duct dB	79	79	71	66	64	64	59	51	83	71	62	59	53	49	52	49	42	38
	Outlet in duct dB	80	82	76	74	72	69	64	59	85	77	69	64	59	54				
0.98m³/s @60%	Inlet in duct dB	77	74	67	63	61	59	54	46	79	67	58	54	49	44	47	44	38	33
	Outlet in duct dB	78	77	72	70	69	65	59	54	82	73	65	61	56	51				
0.80m³/s @50%	Inlet in duct dB	74	67	62	59	57	54	48	39	75	62	54	49	44	39	42	38	32	27
	Outlet in duct dB	76	70	67	66	64	59	53	48	78	68	60	56	51	46				



TECHNICAL DATA - HRPSL950EC

SPECIFIC FAN POWER - FOR EACH FAN

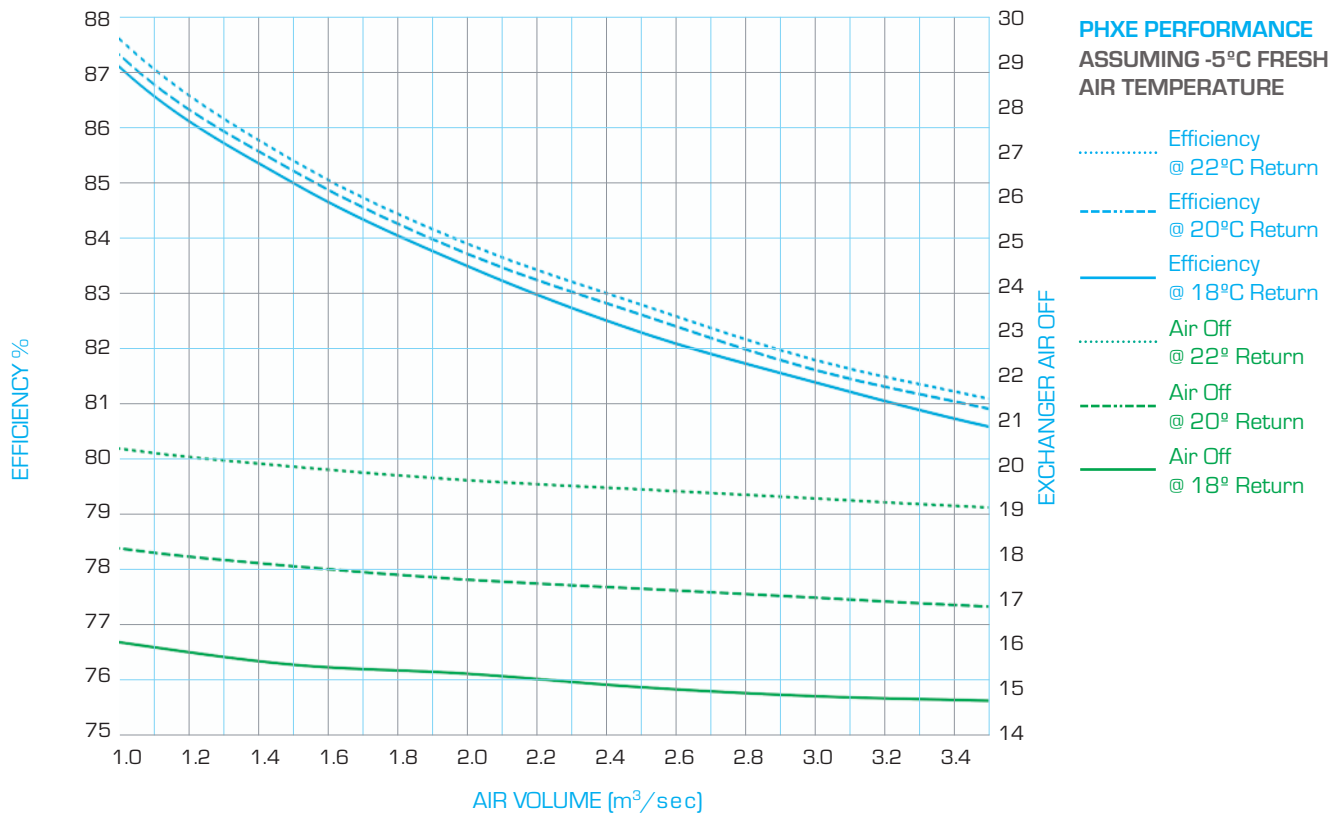
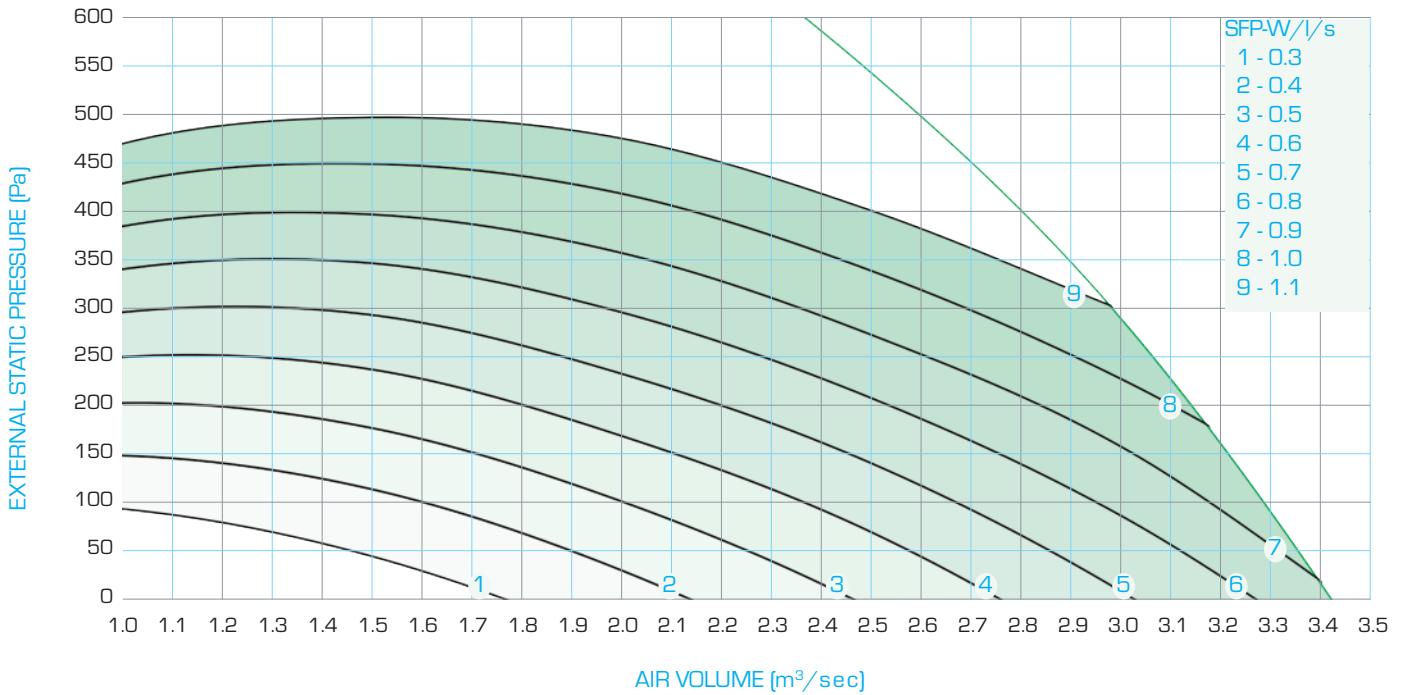



TECHNICAL DATA - HRPSL1100EC

FAN SPEED

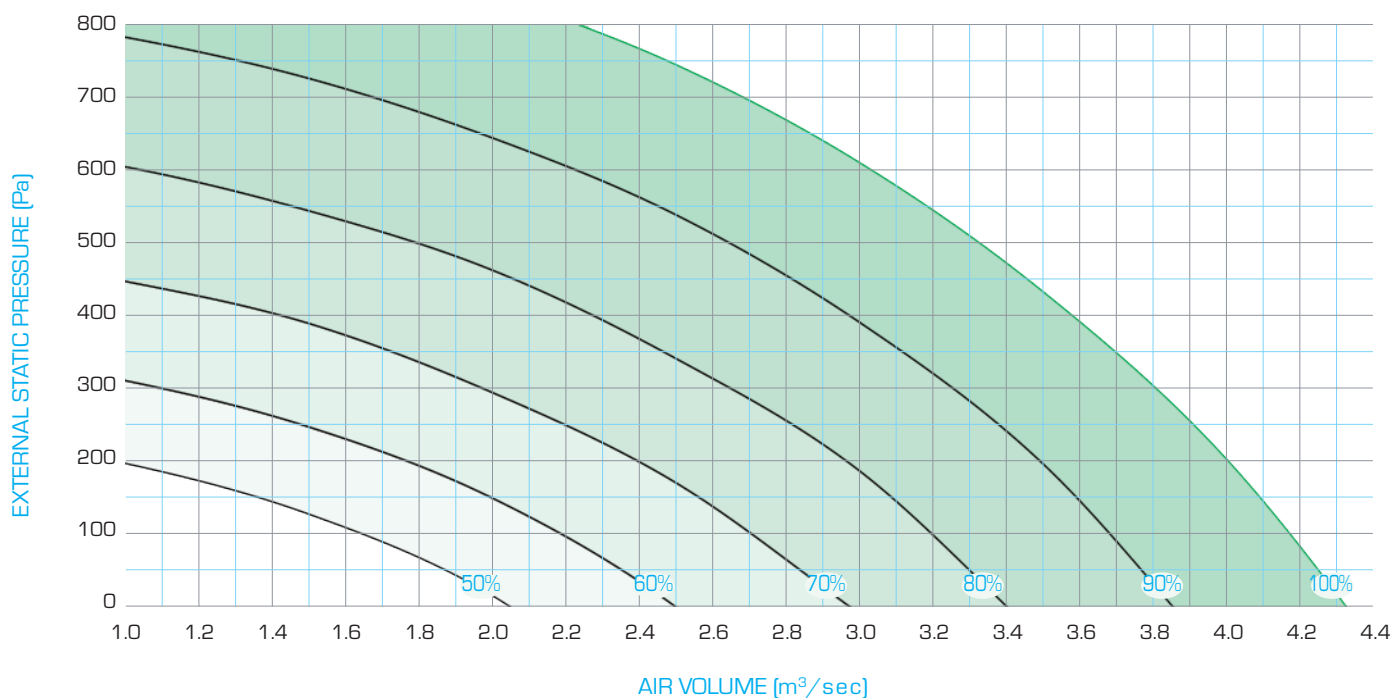

ELECTRICAL DATA per FAN Maximum drawn current for UNIT - 40A (fuse/ circuit breaker rating does NOT include ancillaries)	MODEL	FAN POWER W	SUPPLY	FLC amps
		HRPSL1100EC	4600	400V 3Ph

HRPSL1100EC @ mid duty		Mid Octave Frequency band / Hz								Total in Duct		In Duct @ 1m		In Duct @ 3m		Breakout @ 1m		Breakout @ 3m	
		63	125	250	500	1k	2k	4k	8k	dB	dB(A)	dB	dB(A)	dB	dB(A)	dB(A)	NR	dB(A)	NR
2.17m³/s @100%	Inlet in duct dB	84	89	84	77	76	75	71	64	92	82	74	69	64	60	63	62	54	51
	Outlet in duct dB	88	94	89	87	84	80	76	70	97	89	81	76	71	66				
1.93m³/s @90%	Inlet in duct dB	82	86	82	75	74	72	67	60	89	80	72	67	62	57	60	59	51	48
	Outlet in duct dB	86	91	86	84	81	77	72	67	94	86	78	73	68	63				
1.70m³/s @80%	Inlet in duct dB	80	84	79	71	71	69	63	56	86	77	68	64	59	54	57	55	48	45
	Outlet in duct dB	83	88	83	81	78	73	68	64	91	83	75	70	65	60				
1.49m³/s @70%	Inlet in duct dB	79	80	74	68	68	65	59	52	83	73	65	60	55	50	53	51	44	40
	Outlet in duct dB	82	84	78	78	75	69	64	60	88	80	71	67	62	57				
1.25m³/s @60%	Inlet in duct dB	79	74	69	64	64	61	54	47	81	69	60	56	51	46	49	45	40	35
	Outlet in duct dB	82	79	74	74	71	65	59	55	85	76	67	63	58	53				
1.03m³/s @50%	Inlet in duct dB	76	68	64	60	60	55	48	42	77	64	56	52	46	42	44	39	34	29
	Outlet in duct dB	79	72	68	70	66	59	53	49	81	71	63	59	53	49				



TECHNICAL DATA - HRPSL1100EC

SPECIFIC FAN POWER - FOR EACH FAN

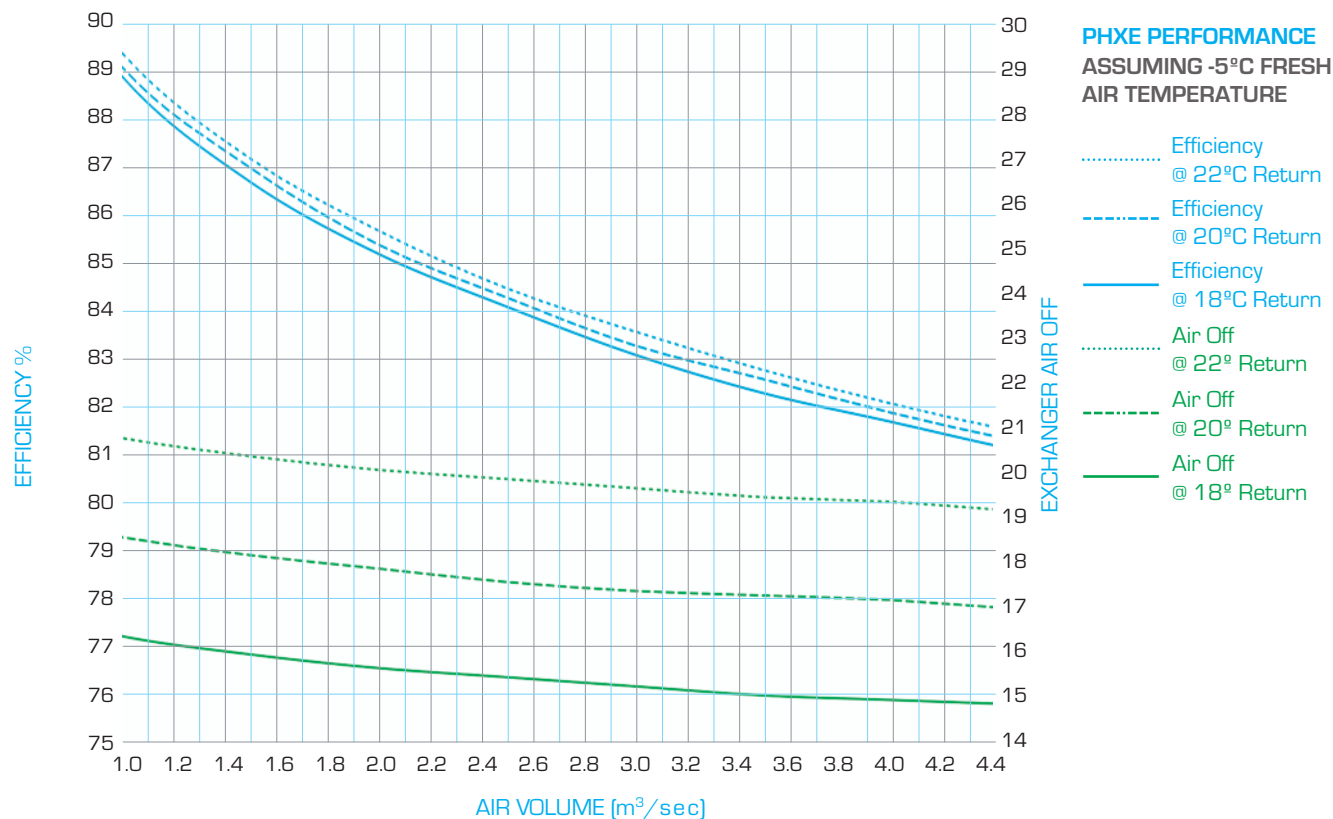
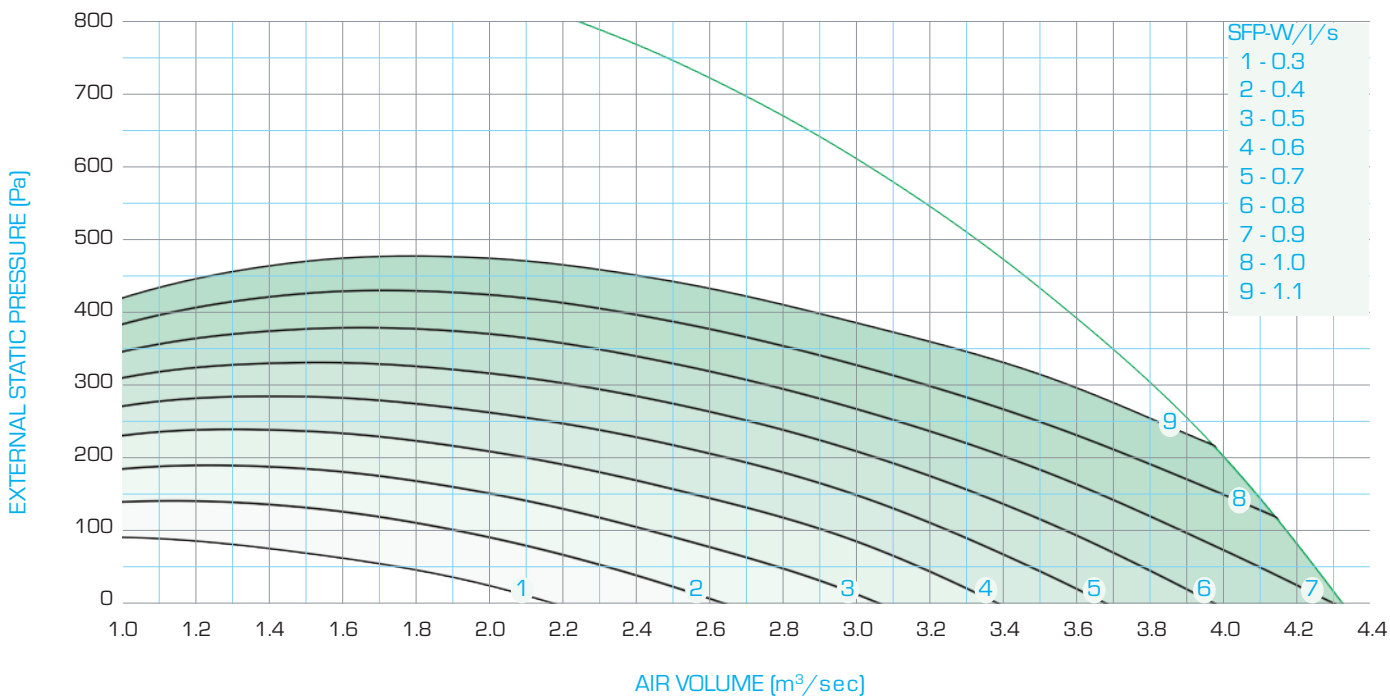

UNIT DIMENSIONS - SIDE BY SIDE ARRANGEMENT - SIDE AND BOTTOM ACCESS

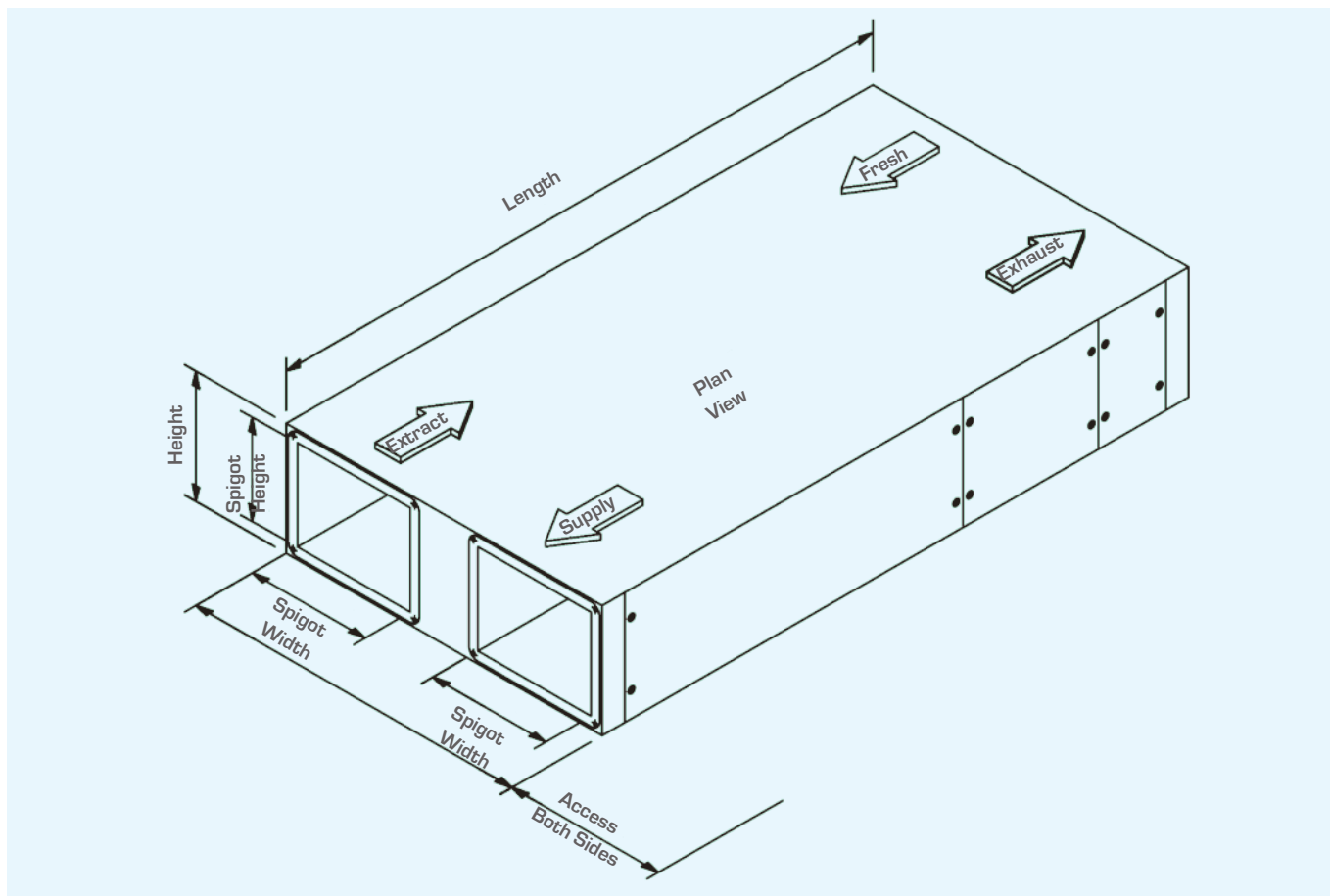

Model	Height	Width	Length	Spigot Width	Spigot Height	Filter Access*	Weight kg internal	Weight kg external
HRPSL250EC	250	750	1450	300	175	425	118	130
HRPSL310EC	310	930	1575	375	235	515	163	179
HRPSL350EC	350	1050	1650	425	275	575	200	220
HRPSL390EC	390	1170	1800	500	315	635	249	273
HRPSL470EC	470	1410	2175	600	400	755	418	459
HRPSL560EC	560	1680	2425	725	485	890	636	700
HRPSL650EC	650	1950	2750	850	590	1025	735	780
HRPSL800EC	800	2400	3100	1075	740	1250	1093	1162
HRPSL950EC	950	2850	3650	1300	890	1475	1771	1867
HRPSL1100EC	1100	3300	3950	1500	1040	1700	2691	2817

Dimensions in mm

*Add 100mm to height for weatherproof unit

*Minimum required for PHXE removal - whole unit width.

*Refer to Sales Office for bottom access clearances.



UNIT DIMENSIONS - STACKED ARRANGEMENT

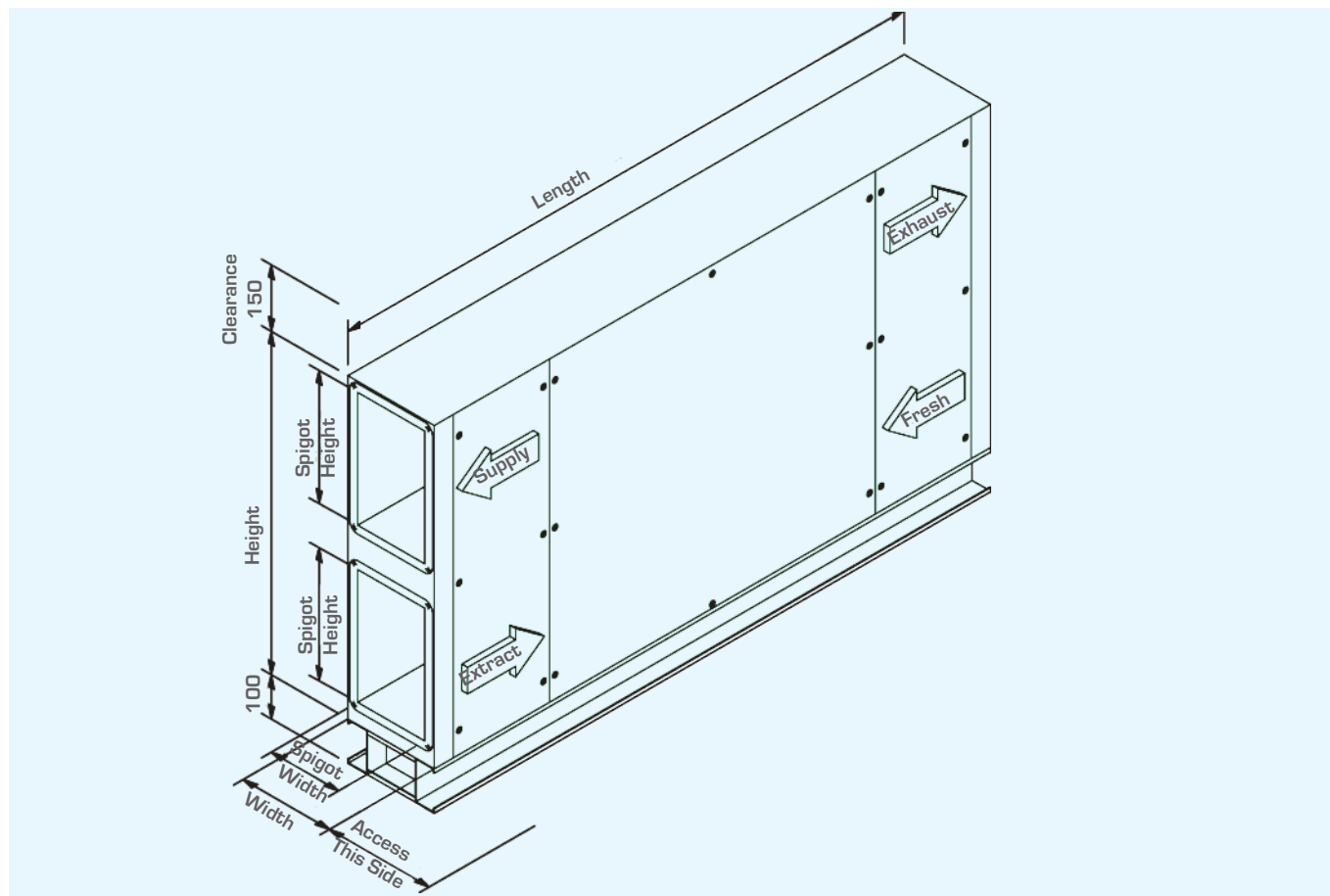

Model	Height	Width	Length	Spigot Width	Spigot Height	Filter Access*	Weight kg internal	Weight kg external
HRPSL250EC	775	225	1450	175	300	275	118	130
HRPSL310EC	955	285	1575	235	375	335	163	179
HRPSL350EC	1075	325	1650	275	425	375	200	220
HRPSL390EC	1195	365	1800	315	500	390	249	273
HRPSL470EC	1435	445	2175	400	600	495	418	459
HRPSL560EC	1705	535	2425	485	725	585	636	700
HRPSL650EC	1950	650	2750	590	850	700	735	780
HRPSL800EC	2400	800	3100	740	1075	850	1093	1162
HRPSL950EC	2850	950	3650	890	1300	1000	1771	1867
HRPSL1100EC	3300	1100	3950	1040	1500	1150	2691	2817

Dimensions in mm

*Building Regulations must be observed

*Add 100mm to height for weatherproof unit.

Minimum required for PHXE removal - whole unit width

ANCILLARIES - ELECTRIC HEATER BATTERY

- Duct-mounted EHBs for single phase operation are manufactured from sheathed rod elements with an integral manual reset thermal cut-out for wiring into control circuit.
- Fitted airflow switch.
- Double skinned galvanised sheet case with flanges to both ends.
- Heating Load kW =
Air Volume m³/s x 1.21 x
Temperature Rise ΔT°C

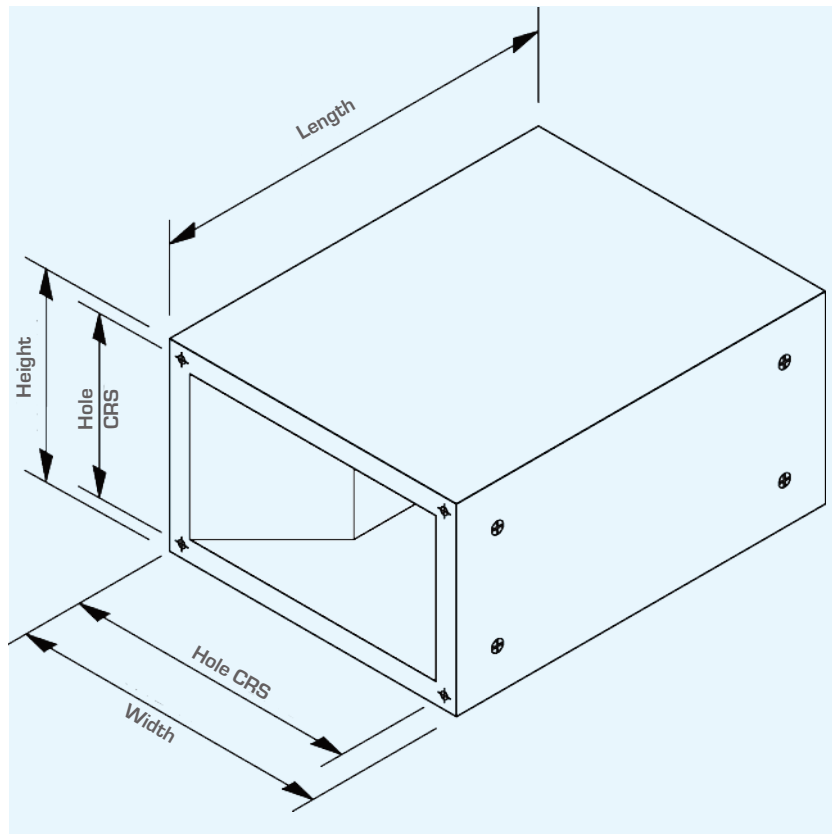

Model/Kw/Phase	Height	Width	Length	CRS Height	CRS Width	Airflow min m ³ /sec	Weight kg
EHD/HRPSL250/1.0/1	225	350	450	195	320	0.04	17
EHD/HRPSL310/2.0/1	285	425	450	255	395	0.08	18
EHD/HRPSL350/2.5/1	325	475	450	295	445	0.09	20
EHD/HRPSL390/3.0/1	365	550	450	335	520	0.10	22
EHD/HRPSL470/5.0/1	445	650	450	420	620	0.20	27
EHD/HRPSL560/9.0/1	535	775	450	505	745	0.35	30
EHD/HRPSL650/12.0/3	640	900	450	620	880	0.40	58
EHD/HRPSL800/15.0/3	790	1125	450	770	1105	0.63	61
EHD/HRPSL950/27.0/3	940	1350	450	920	1330	1.08	80
EHD/HRPSL1100/33.0/3	1150	1550	450	1070	1530	1.32	92

Dimensions in mm

ANCILLARIES - LPHW COIL

- Duct-mounted LPHW batteries from copper tubes mechanically bonded to aluminium fins supplied with standard BSP male connections
- Coil case fully boxed and insulated with installed nutserts for fitting directly to unit
- LPHW valve and actuator supplied as optional extra

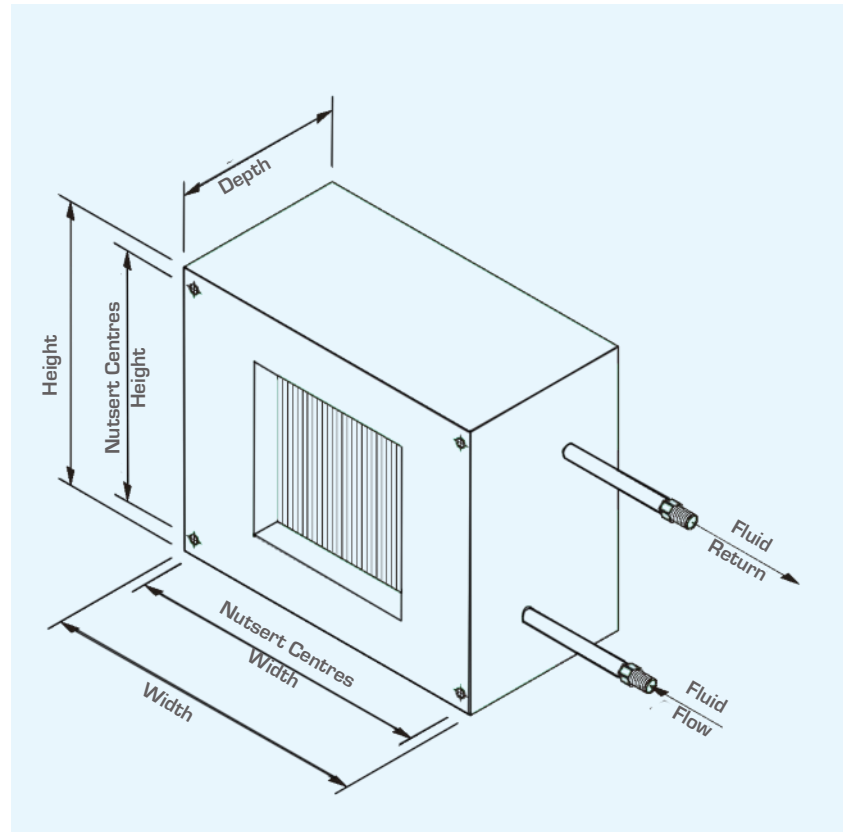

Model/Kw	Height	Width	Length	CRS Height	CRS Width	Rating Kw	Airflow min m ³ /sec	Weight kg
LPHW/HRPSL250/1.0	215	340	200	195	320	1.0	0.08	9
LPHW/HRPSL310/2.0	275	415	200	255	395	2.0	0.18	12
LPHW/HRPSL350/3.0	350	465	200	295	445	2.5	0.20	14
LPHW/HRPSL390/3.0	390	540	200	335	520	3.0	0.25	17
LPHW/HRPSL470/5.0	470	640	200	420	620	5.0	0.50	21
LPHW/HRPSL560/9.0	560	765	200	505	745	9.0	0.70	27
LPHW/HRPSL650/12.0	650	890	200	620	880	12.0	1.20	31
LPHW/HRPSL800/15.0	800	1115	200	770	1105	15.0	1.90	42
LPHW/HRPSL950/27.0	950	1340	200	920	1330	27.0	3.00	53
LPHW/HRPSL1100/33.0	1100	1540	200	1070	1530	33.0	4.00	72

Dimensions in mm

ANCILLARIES - ATTENUATOR

- Galvanised sheet steel case with 20mm Mez flanges to both ends
Suitable for fitting directly to unit
- 100mm or 50mm airways options

Centre Frequency Hz	63	125	250	500	1k	2k	4k	8k
Insertion Loss dB100	6	12	23	40	51	51	41	29
Insertion Loss dB50	10	20	36	55	55	55	55	55

Dimensions in mm

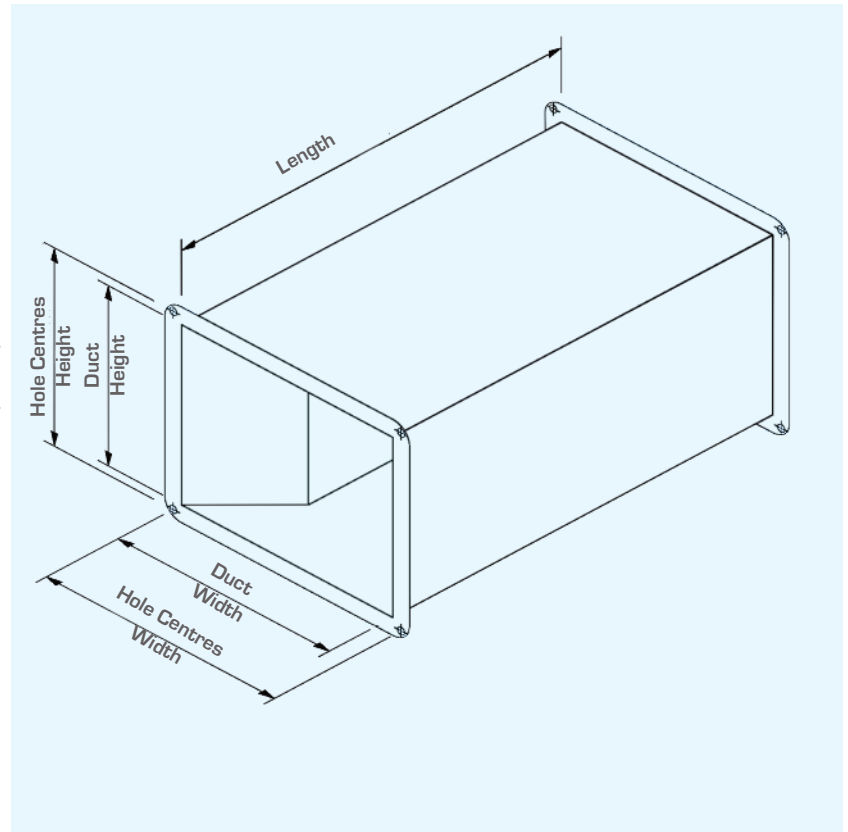

Model	Duct Height	Duct Width	Length	CRS Height	CRS Width	100 mm Weight kg	50 mm Weight kg
AS/HRPSL250/120	175	300	1200	195	320	16	17
AS/HRPSL310/120	235	375	1200	255	395	22	23
AS/HRPSL350/120	275	425	1200	295	445	27	29
AS/HRPSL390/120	315	500	1200	335	520	29	33
AS/HRPSL470/120	395	600	1200	420	620	40	41
AS/HRPSL560/120	485	725	1200	505	745	54	57
AS/HRPSL650/120	590	850	1200	620	880	65	72
AS/HRPSL800/120	740	1075	1200	770	1105	95	108
AS/HRPSL950/120	890	1300	1200	920	1330	125	134
AS/HRPSL1100/120	1040	1500	1200	1070	1530	134	180

Dimensions in mm



ANCILLARY CURVES

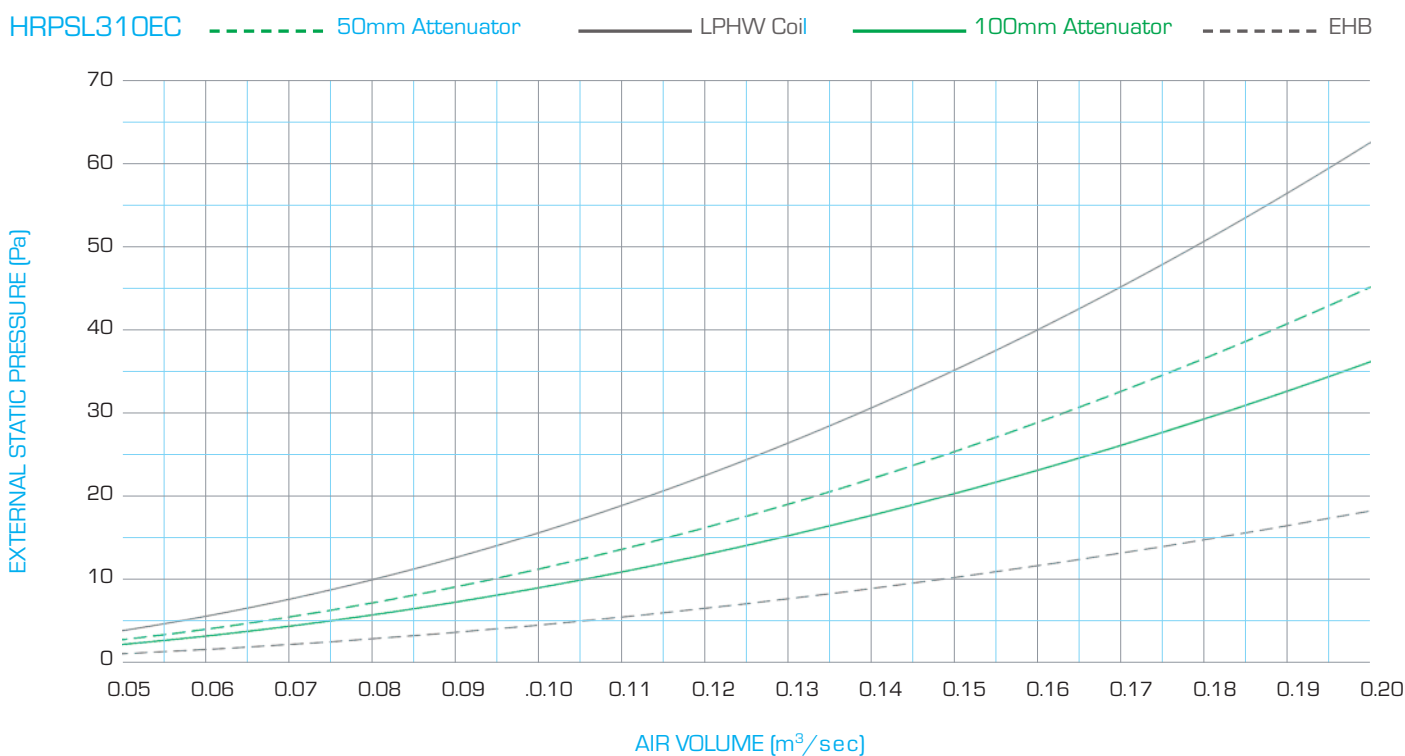
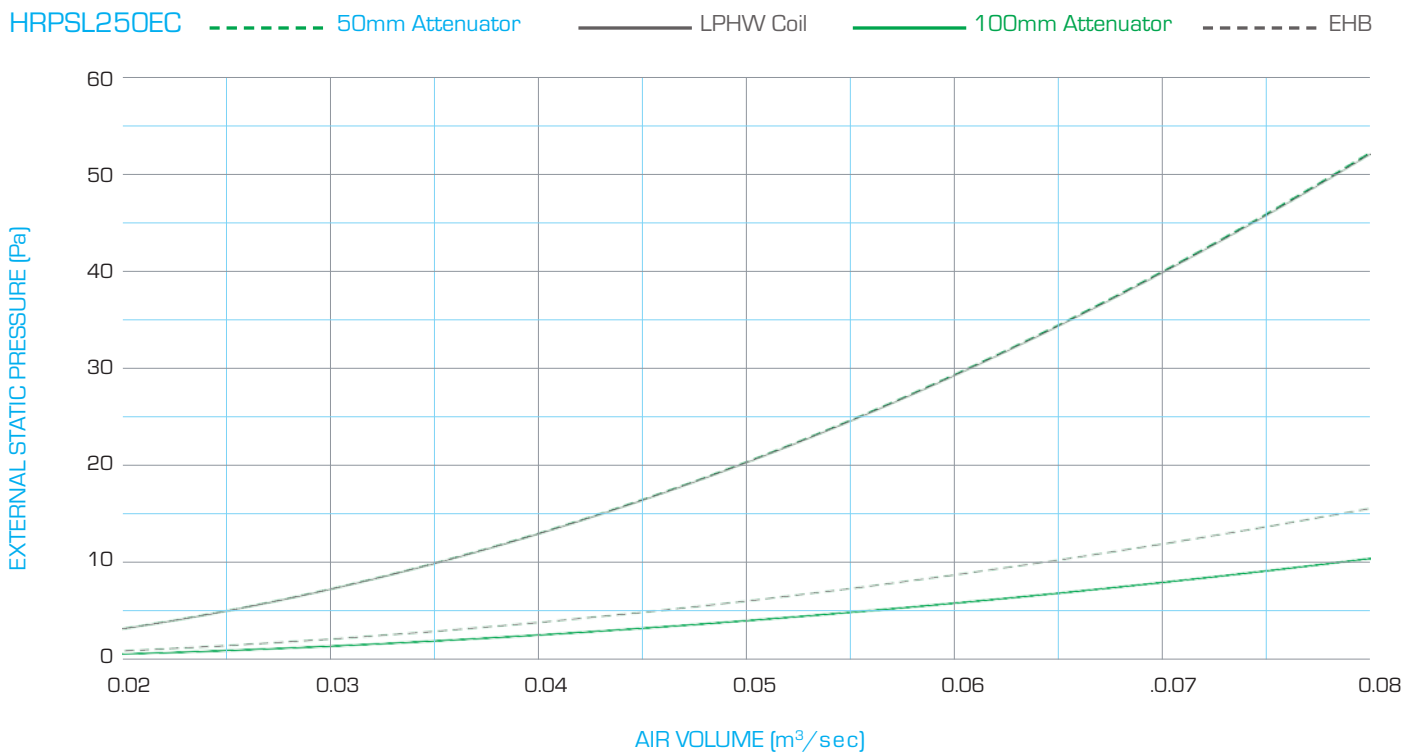



ANCILLARY CURVES

HRPSL350EC - - - - - 50mm Attenuator ——— LPHW Coil ——— 100mm Attenuator - - - - - EHB

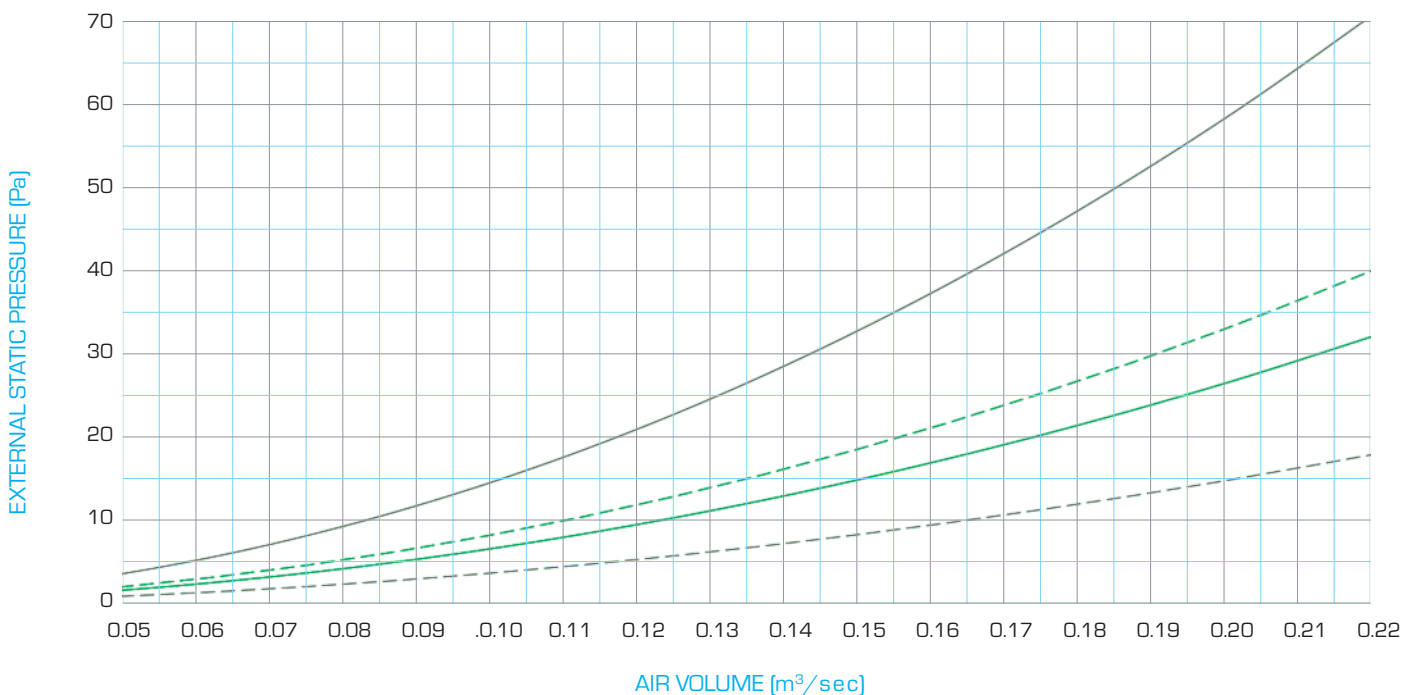

HRPSL390EC - - - - - 50mm Attenuator ——— LPHW Coil ——— 100mm Attenuator - - - - - EHB

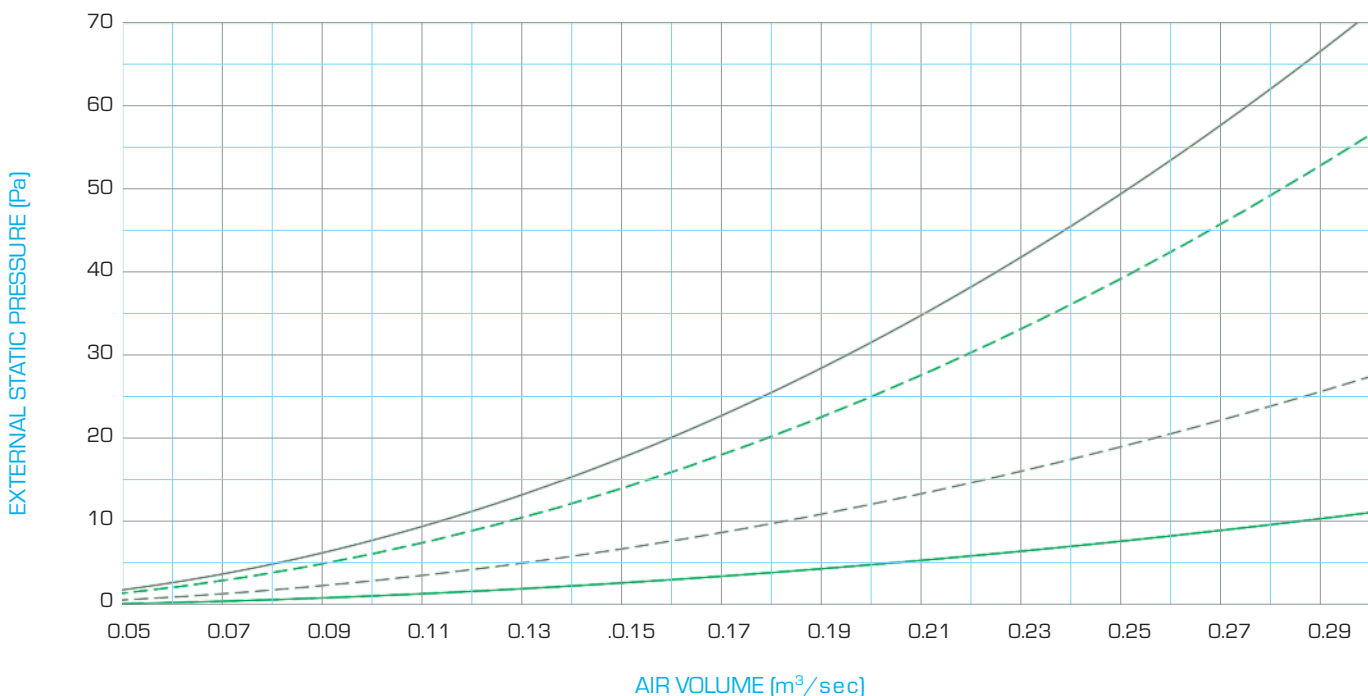



ANCILLARY CURVES

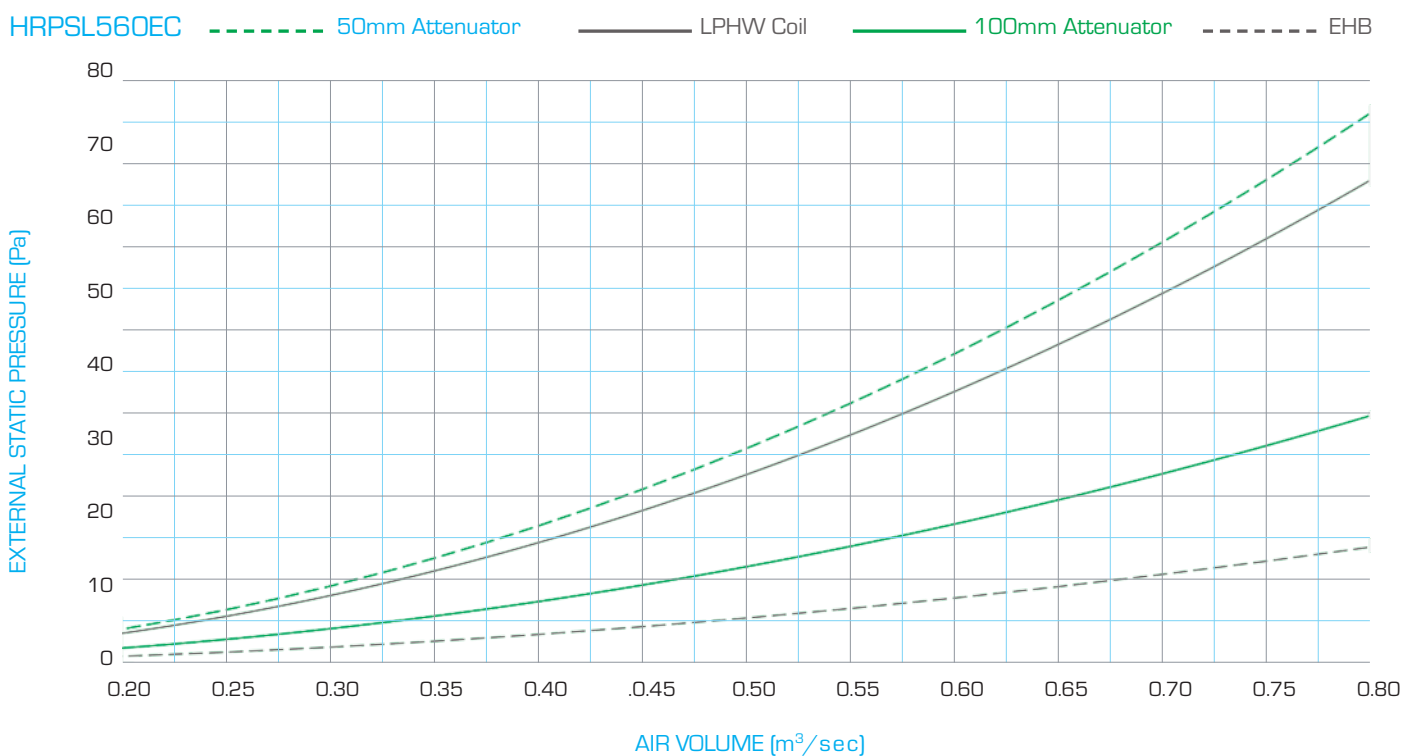
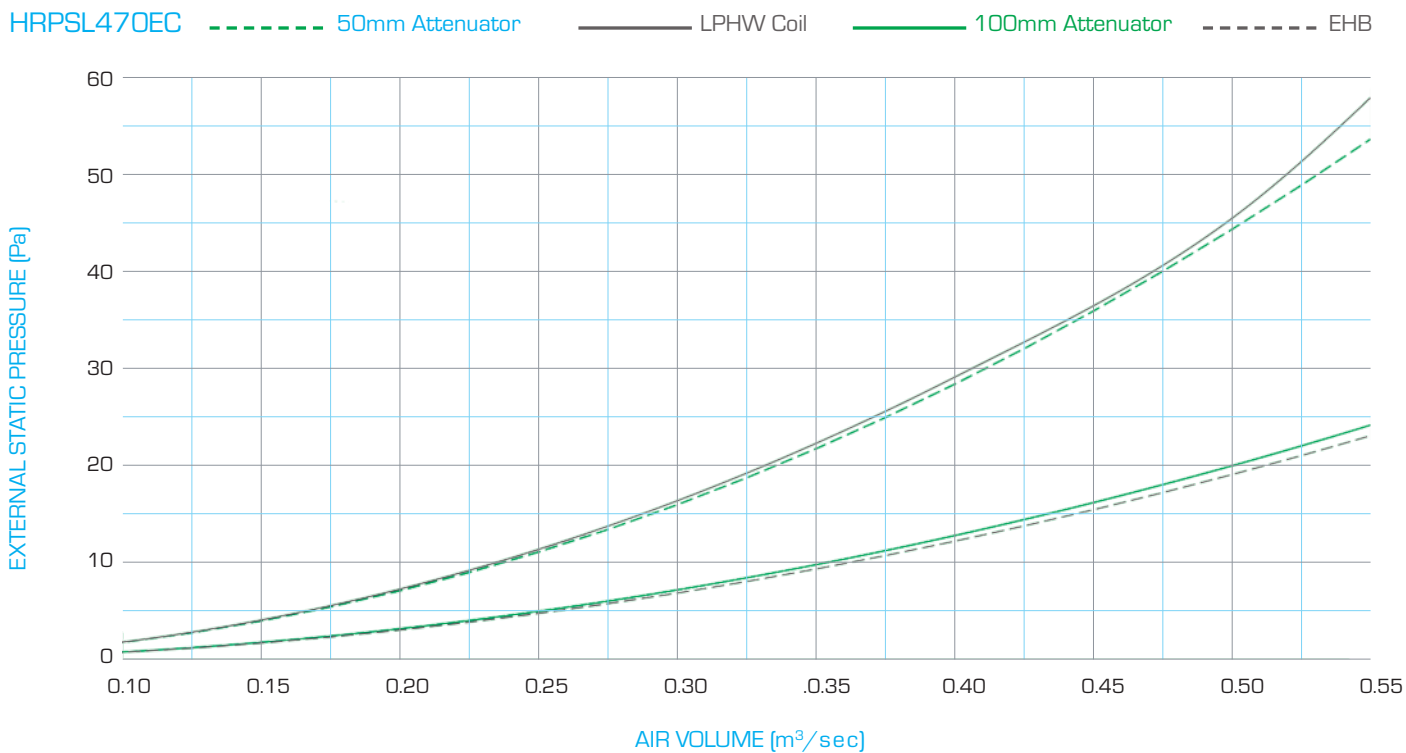



ANCILLARY CURVES

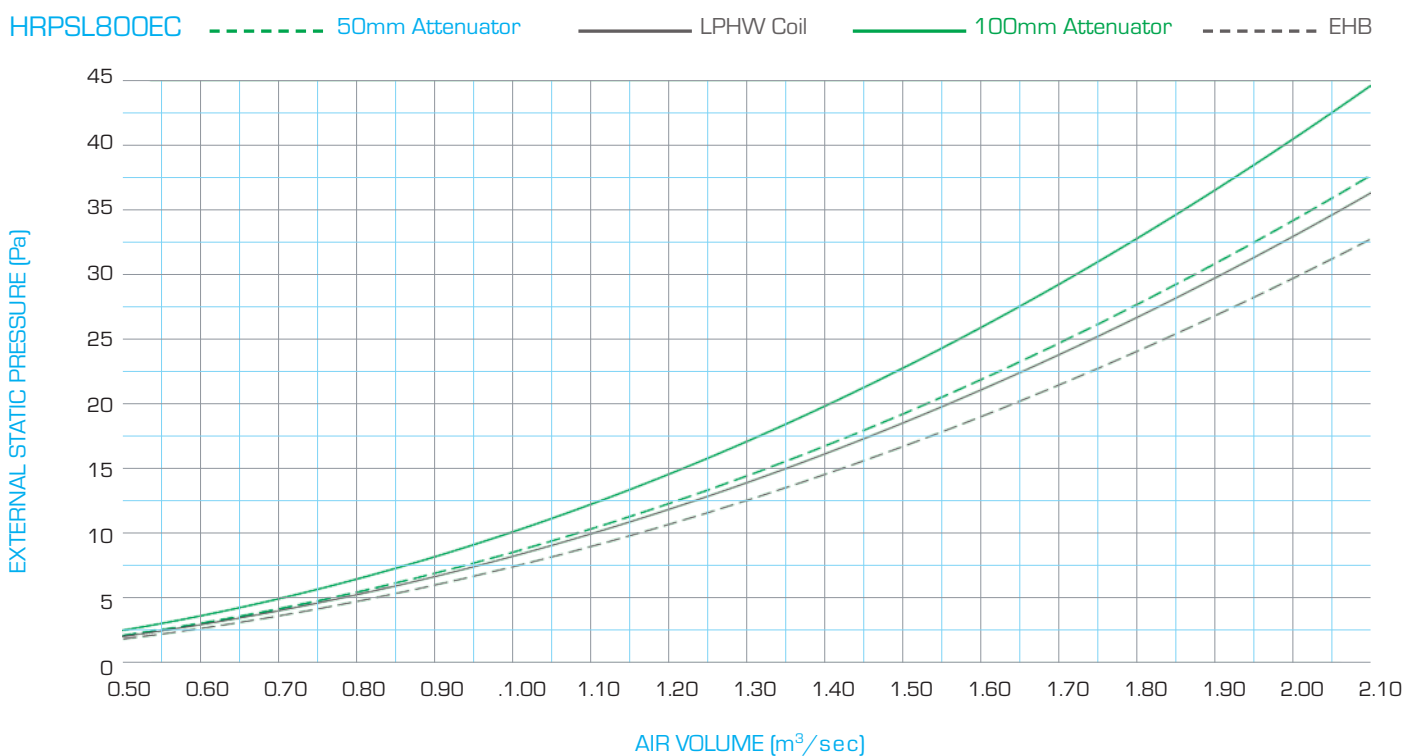
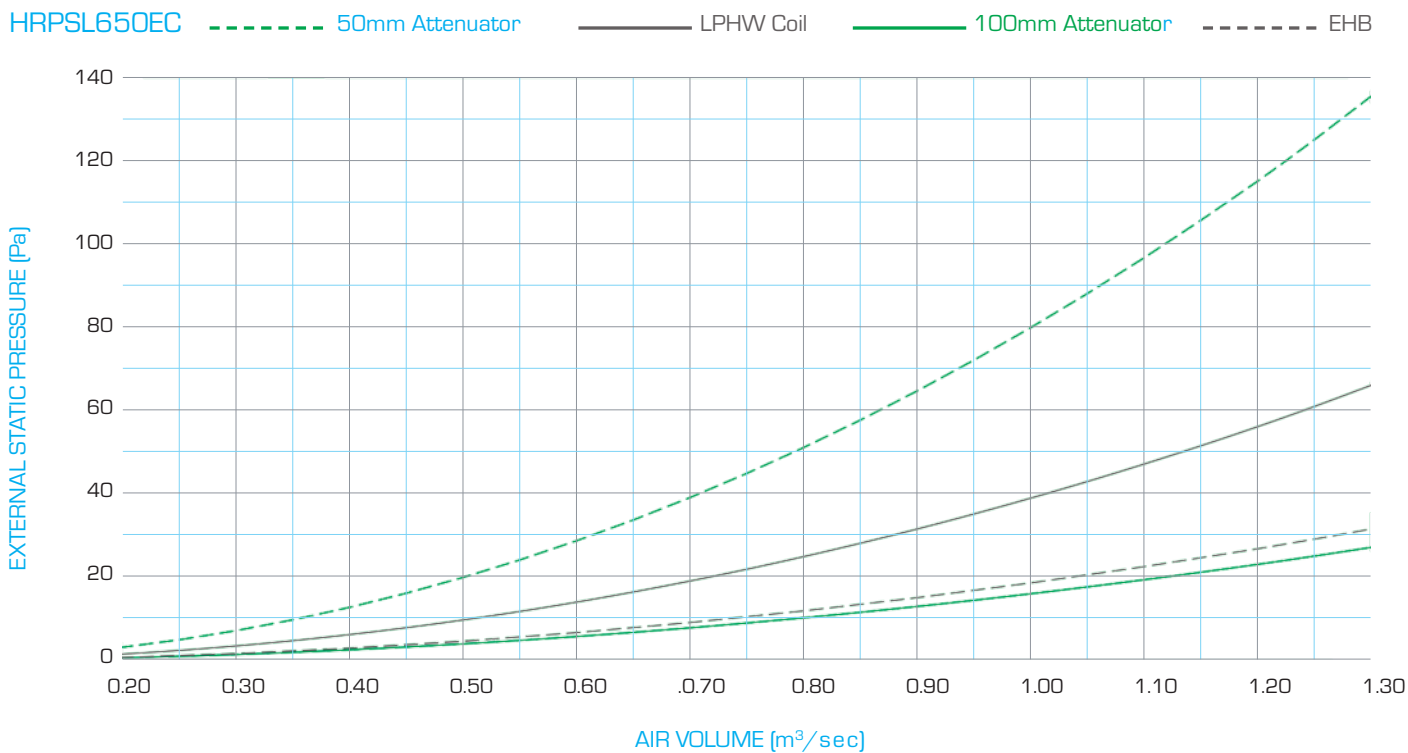



ANCILLARY CURVES

HRPSL950EC - - - - - 50mm Attenuator ——— LPHW Coil ——— 100mm Attenuator - - - - - EHB

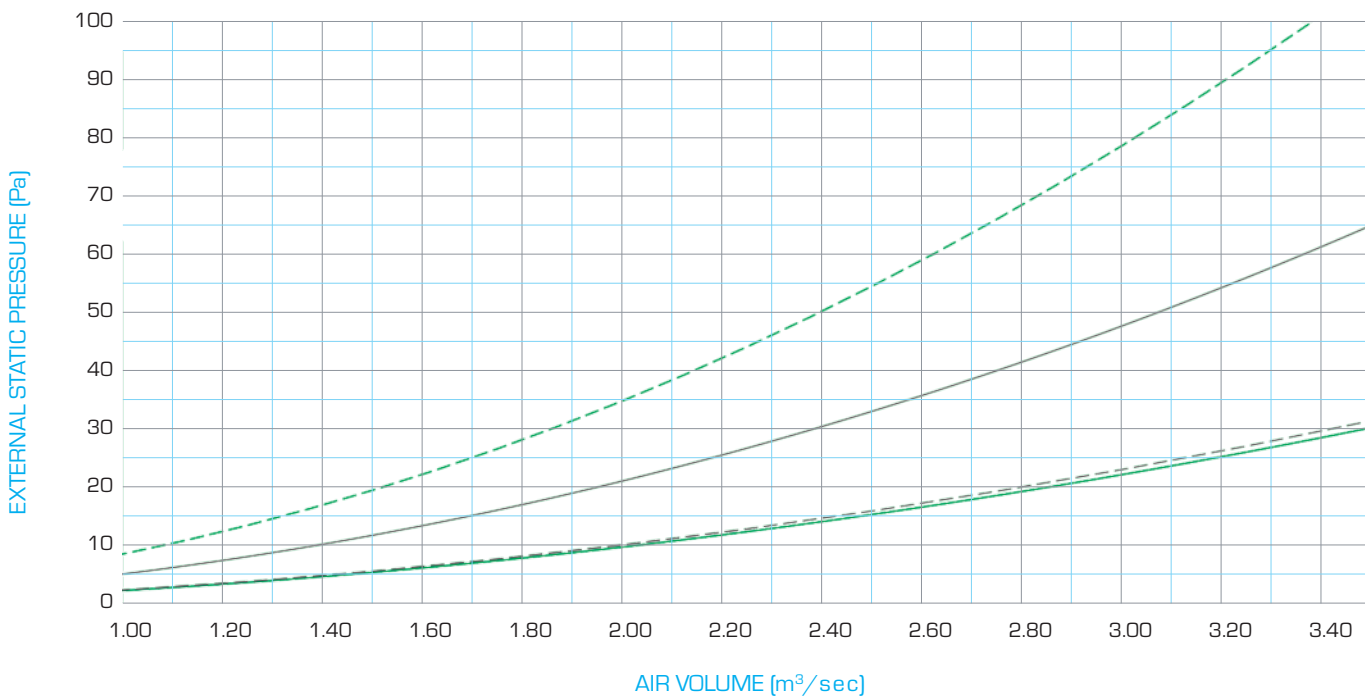

HRPSL1100EC - - - - - 50mm Attenuator ——— LPHW Coil ——— 100mm Attenuator - - - - - EHB

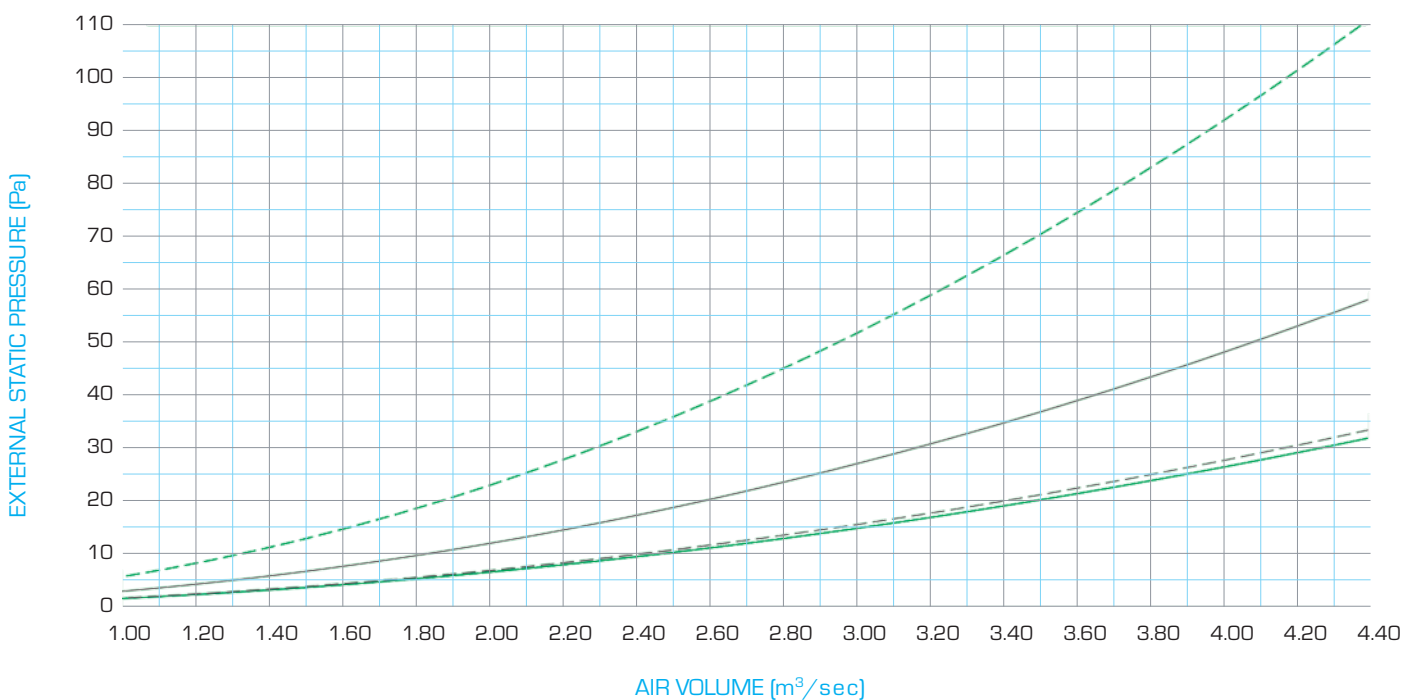

CONTROLS



- Fully fitted and pre-wired controls available for all units - this offers many benefits:
- Reduced site costs as most of the wiring is already carried out.
- Peace of mind for seamless integration.
- Controls are pre-tested with full technical support.
- To cover as many projects as possible we offer two ranges - Basic and Enhanced.
- Basic range will suit many applications both commercially and technically.
- They are used in applications without supplementary heating.
- If Basic panel does not offer all the functions required Enhanced panels will.
- Enhanced panels offer heating and cooling control and are programmable to suit specific projects.
- Bespoke control panel available to provide a complete controls solution.

CONTROL PANEL BASIC - HRCPB-PX

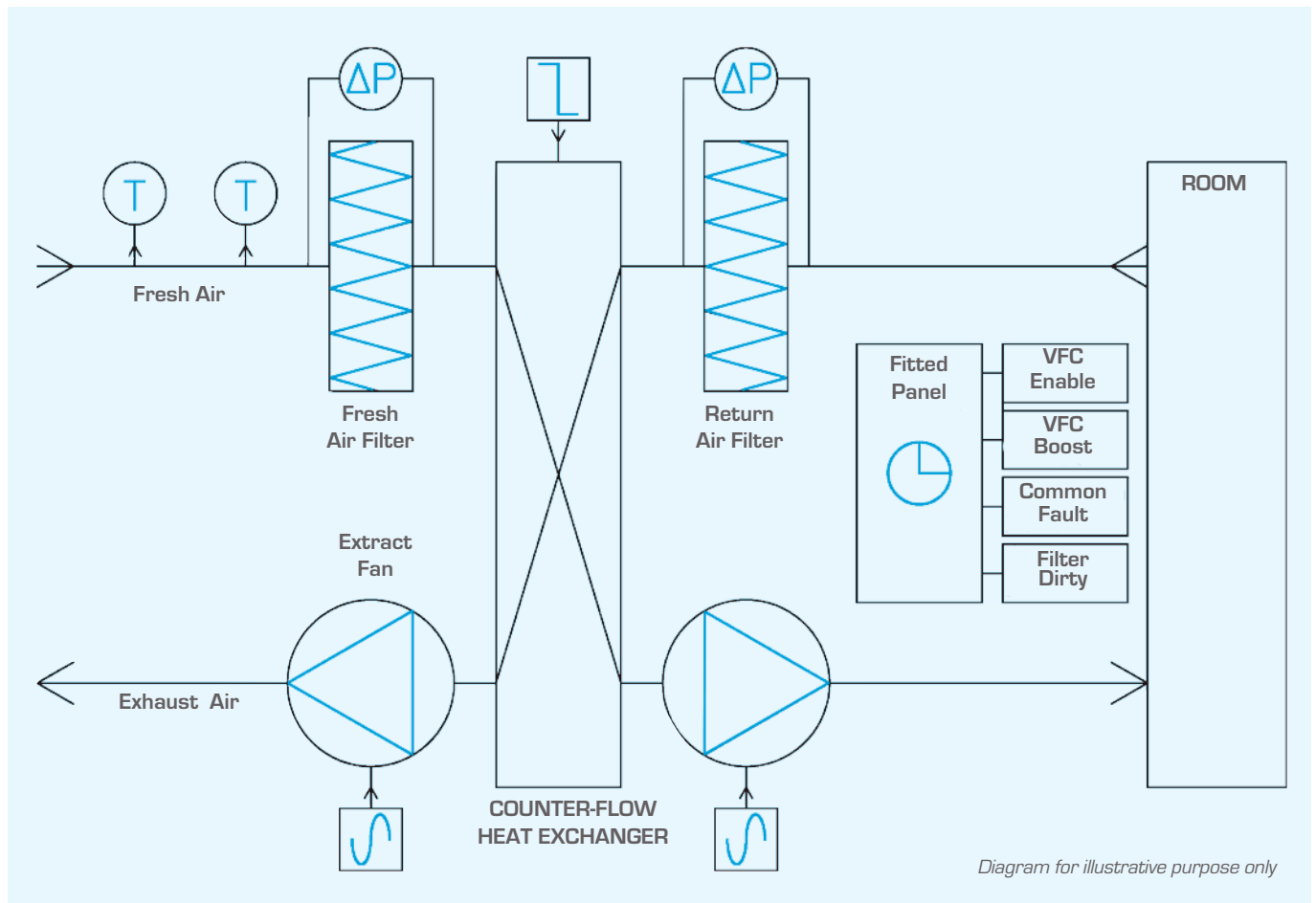

- Fitted and pre-wired as standard.
 - IP56 rated enclosure.
 - Mains fuses and individual fan fuses (MCBs and contactors for 3 phase version).
 - Trickle/Boost operation.
 - Face and by-pass damper motor control via fitted sensors.
 - Optional 7-day time clock if required.
 - Optional remote speed control.
- Room controller not available.

- **Fascia Fitted:**
 - Panel live indicator.
 - Illuminated enable switch.
 - Common fault indicator.
 - Dirty filter indicator.
- **Customer Connections:**
 - VFC BMS enable
 - VFC BMS boost
 - Common fault BMS link.
 - Filter dirty BMS link.
- **Mains Input: To suit unit fan motors:**
 - 230V, 50Hz, 1 phase - **HRCPB-PX-1**.
 - Or 400V, 50Hz, 3 phase & N - **HRCPB-PX-3**.

CONTROL PANEL ENHANCED - HRCPE-PX

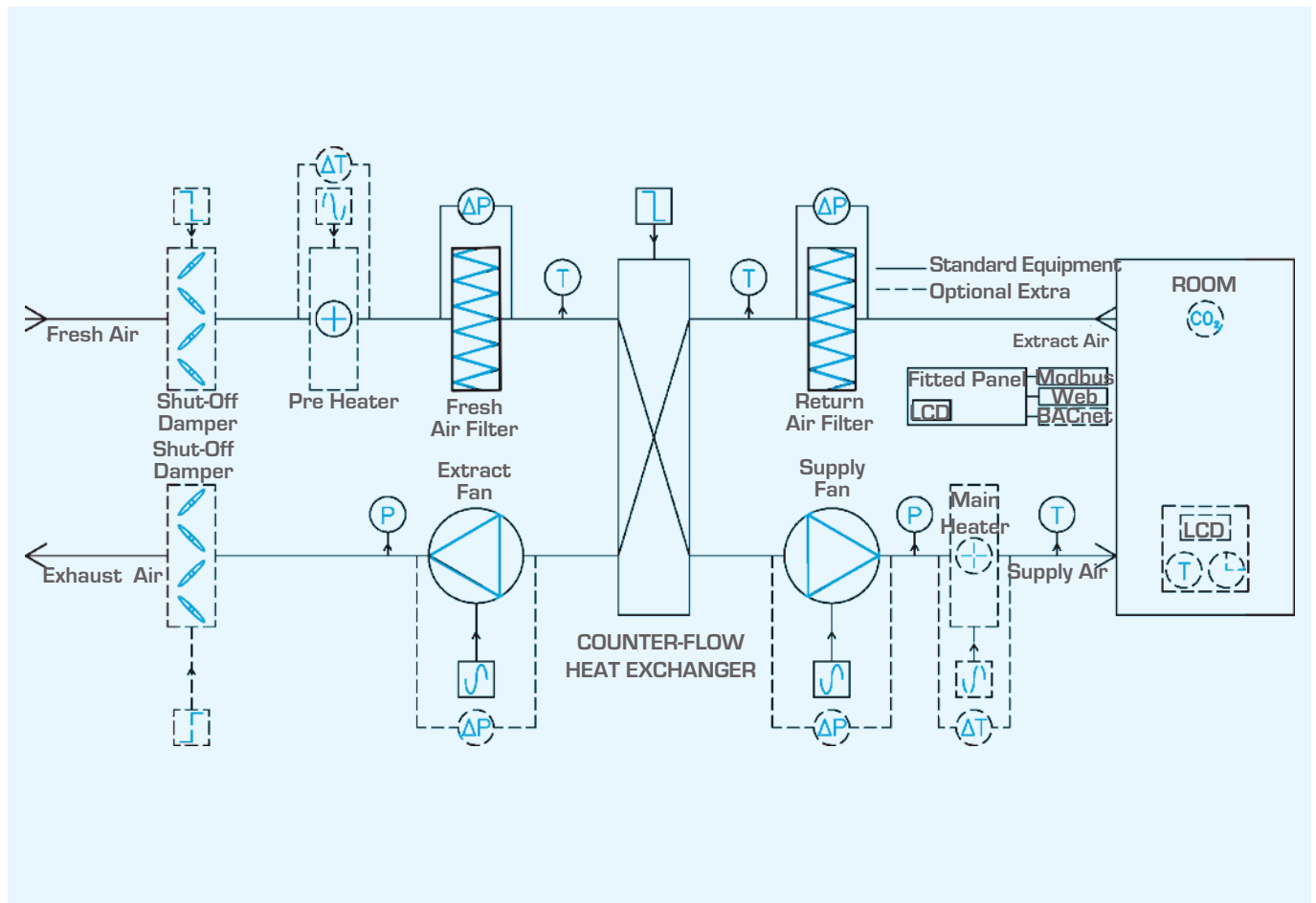

Diagram for illustrative purpose only

- Our enhanced panel offers total flexibility to provide specific solutions. We can provide::
 - > Heating and cooling control.
 - > Pre-heaters.
 - > Shut off dampers.
 - > Fan speed via pressure, volume.
 - > Demand ventilation via CO₂.
 - > Room controller.
 - > Modbus or BACnet.
 - > Logging facility and web interface.



HRU SPECIFICATION

Case Construction

- Models 250 to 560 are constructed from a rigid frameless system, using folded galvanised steel. Comprising 25mm double skin panels with high density mineral infill.
- Internal side by side model up to size 560 have a 40mm base panel to reduce noise breakout through a ceiling void.
- Models 650 to 1100 are a penta-post type frame system. Comprising 25mm double skin panels with high density mineral infill.
- Externally mounted models have coated steel with pitched roof. Models 250 to 560 are powder coated. Models 650 to 1100 are plastisol coated.
- Access for filters are quarter turn quick release panels. Remaining access panels are via screw fixings.
- Unit access is side as standard. Bottom access is also available for interior units

Counter-flow Plate Heat Exchanger

- Lightweight aluminium construction complete with Integral face and bypass damper for summer operation. Counter-flow design to give increased efficiency typically greater than 80%. Heat exchangers are leak tested and are Eurovent certified. A galvanised drain pan is also fitted.

EC Motor and Fan

- Direct drive, Single Inlet, backward curved impeller. Driven by a variable speed EC motor. The motor accepts a 0-10v signal to control fan speed. Motor efficiency class is IE4.
- Motor and impeller statically and dynamically balanced to ISO 1940 Part 1. Permissible ambient temperature - 15°C to +55°C with over temperature protection.

Filters

- Supply Filter – Grade F7 mini-pleat glass fibre panel filter. EN779:2012.
- Extract Filter – Grade M5 polypropylene panel filter. EN779:2012.

Heater Modules

- Electric – Manufactured from sheathed rod elements. Integral thermal cut out, manual reset for wiring into the control circuit. Double skin galvanised steel case with flanges. Suitable for mounting to the unit. Internal mounting only. Weatherproof options are available.
- LPHW – Manufactured from copper tubes bonded to aluminium fins. Connection is male BSP. Coil case is fully boxed and insulated. Internal mounting only. Nutserts are installed to allow fitting to the unit. Weatherproof and duct mounted versions are available.

Silencers

- Galvanised sheet steel case with 20mm Mez flanges both ends. Suitable for mounting directly to the unit. Available with 100mm and 50mm airways. Powder coated silencers are also available.

PROJECT SPECIFIC AIR HANDLING UNITS - STP/STR

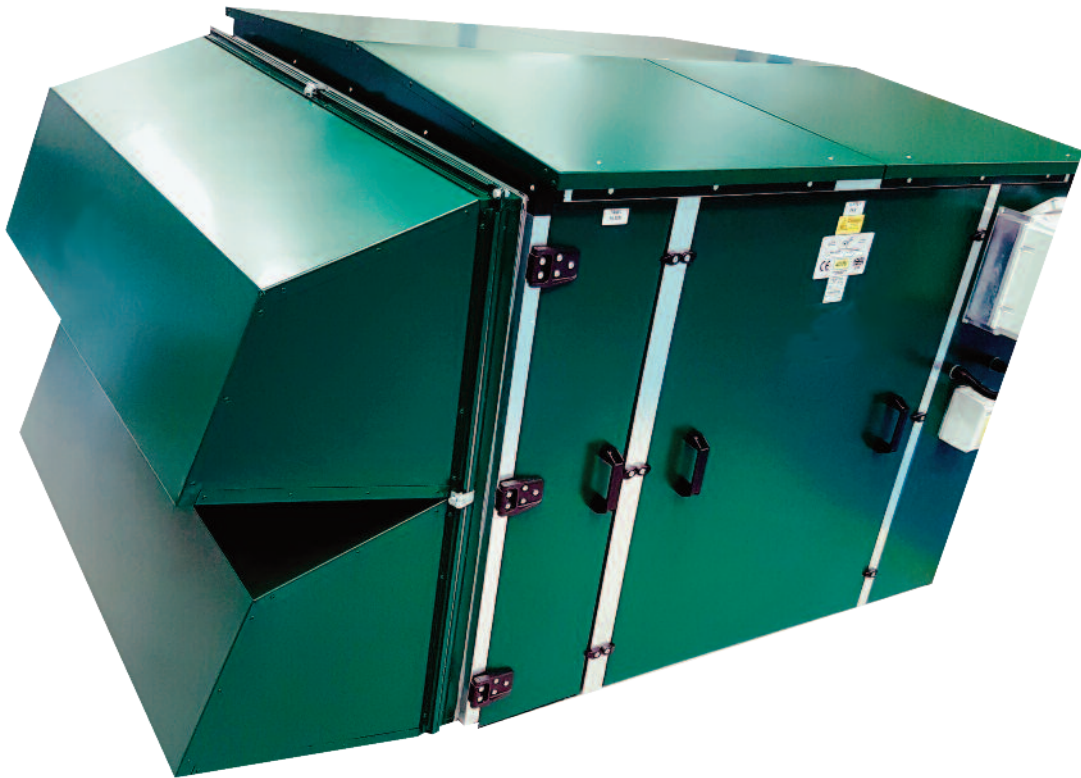

- If the HR-SL range cannot offer the solution you require we can offer bespoke units for your specific project.
- Units are available up to **20 m³/s**. Cases can be constructed with **25mm or 50mm** panels. Multiple configurations and non-standard sizes are available.
- A wide range of components are available including:
 - > Duplex fan arrangement or run and stand by.
 - > Plate heat exchangers, thermal wheels, run-around coils.
 - > Heaters – LPHW, Electric, Gas burners and DX heat pump coil.
 - > Cooling Coils DX or Chilled Water and Humidifiers.
 - > Panel Filters, Bag Filters, Carbon.
 - > In built silencers.
 - > Control Panels.
 - > HTM and Coastal specifications available.

Other Vectaire Products

Whole House Mechanical Ventilation

MVHR, MEV, dMEV

Midi & Midi BY-AT (MVHR)

- For wall or loft installation in homes and offices
- **Midi BY-AT with integral acoustic attenuation - very low noise levels**
- Summer bypass and frost-stat
- Up to 94% heat exchange efficiency - sfp from 0.50 W/l/s
- Up to 95 l/s at 50Pa - max 101 l/s capacity
- Models with integral humidistat
- Commissioned via integral LCD or remote LCD commissioning unit

Maxi & Maxi BY-AT (MVHR)

- For wall or loft installation in homes and offices
- **Maxi BY-AT with integral acoustic attenuation - very low noise levels**
- Summer bypass and frost-stat
- Up to 92% heat exchange efficiency - sfp from 0.40 W/l/s
- **Up to 163 l/s at 50Pa - max 177 l/s capacity**
- Models with integral humidistat
- Commissioned via integral LCD or remote LCD commissioning unit

MaxiPlus-BY & MaxiPlus/BY/AT (MVHR)

- For wall or loft installation in homes and offices
- **MaxiPlus/ BY/AT with integral acoustic attenuation - very low noise levels**
- Summer bypass and frost-stat
- Up to 89% heat exchange efficiency - sfp from 0.46 W/l/s
- **Up to 230 l/s at 50Pa - max 238 l/s capacity**
- Models with integral humidistat
- Commissioned via integral LCD or remote LCD commissioning unit

EVO200 & EVO250 (MVHR)

- For in-line installation in homes and offices
- Summer bypass and frost-stat
- Up to 94/88% heat exchange efficiency
- Up to 74/80 litre/sec at 50Pa - max 81/85 l/s capacity
- Specific Fan Power from 0.64/0.70 W/l/s
- Models with integral humidistat
- Commissioned via remote LCD commissioning unit

-EVO220 (MVHR)

- For in-line installation in homes and offices
- Summer bypass and frost-stat
- Up to 87% heat exchange efficiency - sfp from 0.55 W/l/s
- Up to 70 l/s at 50Pa - max 75 l/s capacity
- Models with integral humidistat
- Commissioned via remote LCD commissioning unit

EVO350 (MVHR)

- For in-line installation in homes and offices
- Summer bypass and frost-stat
- Up to 88% heat exchange efficiency - sfp from 0.67 W/l/s
- Up to 107 l/s at 50Pa - max 116 l/s capacity
- Models with integral humidistat
- Commissioned via remote LCD commissioning unit

Studio (MVHR)

- For in-line installation in multi-occupancy establishments
- With and without summer bypass and frost-stat
- Up to 80% heat exchange efficiency - sfp from 0.91 W/l/s
- Up to 55 l/s at 50Pa - max 59 l/s capacity
- Models with integral humidistat
- Commissioned via remote LCD commissioning unit

Mini (MVHR)

- For in-line installation in multi-occupancy establishments
- With and without summer bypass and frost-stat
- Up to 83% heat exchange efficiency - sfp from 1.11 W/l/s
- Up to 30 l/s at 50Pa - max 34 l/s capacity
- Commissioned via remote LCD commissioning unit

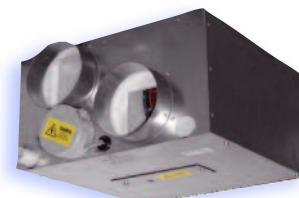
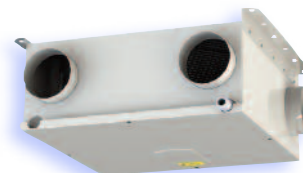
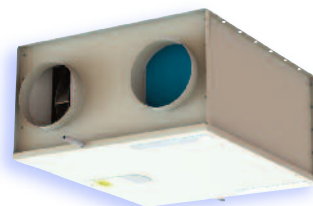
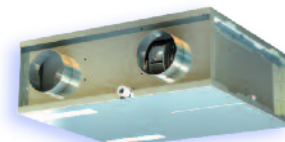

Other Vectaire Products

Whole House Mechanical Ventilation - MVHR, MEV, dMEV



MBOX125/2DC-B (MEV)

- For in-line installation in homes and offices
- Ultra low profile - less than 184mm deep
- Up to 97 l/s at 50Pa - max 108 l/s capacity
- sfp from 0.20 W/l/s
- Purge option factory set
- Available with 204mm x 60mm spigot
- Continuous running - choice of trickle and boost speeds



MBOX200/2DC (MEV)

- For in-line installation in homes and offices
- Up to 233 l/s at 50Pa - max 251 l/s capacity
- sfp from 0.27 W/l/s
- Purge option factory set
- Available with 220mm x 90mm spigot
- Continuous running - choice of trickle and boost speeds



Elegance (dMEV)

- Continuous running 3 speed (2 trickle speeds and boost) axial fan
- For installation in all domestic wet rooms
- Up to 26.9 litre/sec capacity - sfp from 0.09 W/l/s
- **Best SFP in Class**
- **EL100 and EL150 - AC motor versions in 100mm and 150mm dia available**



Elix (dMEV)

- Continuous running 3 speed (2 trickle speeds and boost) centrifugal fan
- EC motor for high efficiency low energy usage
- For installation in all domestic wet rooms
- Up to 28 litre/sec capacity - sfp from 0.14 W/l/s
- **Best SFP in Class**
- **ELX100 - AC motor version in 100mm dia available**



ELPREX (dMEV)

- Continuous running 4 speed (1 trickle and choice of 3 boost speeds) centrifugal fan
- Energy efficient motor
- For installation in walls and ceilings in all kitchens
- Up to 60 litre/sec capacity - sfp from 0.35 W/l/s



E-Smile (dMEV)

- Continuous running 3 speed (2 trickle speeds and boost) axial fan
- Up to 21 litre/sec capacity
- Specific Fan Power from 0.37 W/l/s



Heatrec1003

- **Single room heat recovery unit**
- EC motors for high efficiency low energy usage
- Recovers up to 75% of heat from extracted, polluted air
- 3 speed for any domestic wet room
- Continuous running - choice of trickle and boost speeds
- Heat exchange tube available in 3 lengths
- **With summer bypass and frost-stat**

Vectaire Ltd

Lincoln Road
Cressex Business Park
High Wycombe
Buckinghamshire
HP12 3RH

Tel: +44(0)1494 522333

Fax: +44(0)1494 522337

Email: sales@vectaire.co.uk

Web: www.vectaire.co.uk

